

BARRE ANTIVIBRANTI PER TORNITURA

The logo for 'MAQ' consists of the letters 'MAQ' in a bold, dark grey font, followed by a stylized orange circular icon with a white arrow pointing to the right.

Simplify Machining™

Tecnologia per eliminare
le vibrazioni nelle lavorazioni
meccaniche.

Utensili brevettati:

- Autoregistranti
- Plug & Play
- Senza manutenzione



SISTEMA PLUG AND PLAY VIBRATION FREE

Durante le lavorazioni meccaniche, sia con sporgenze elevate (11-15xD), che ridotte (3-6xD) si generano delle vibrazioni con:

- danneggiamento di pezzi e superfici
- scheggiatura e rottura degli inserti da taglio
- aumento dei costi di produzione.

Il sistema **MAQ** **NEUTRALIZZA LE VIBRAZIONI** degli utensili.

La frequenza delle vibrazioni varia per il consumo degli inserti, per i diversi tipi di materiale lavorato ed i parametri macchina utilizzati.

Privo di regolazioni, Il sistema **MAQ** **SI ADATTA AUTOMATICAMENTE** a tutte le condizioni di lavoro garantendo:

- riduzione dei tempi di lavoro
- miglioramento della qualità delle superfici
- diminuzione delle tolleranze
- elevata ripetibilità dei processi.



BARRE ANTIVIBRANTI

4a GENERAZIONE

Anelli di gomma con olio smorzante

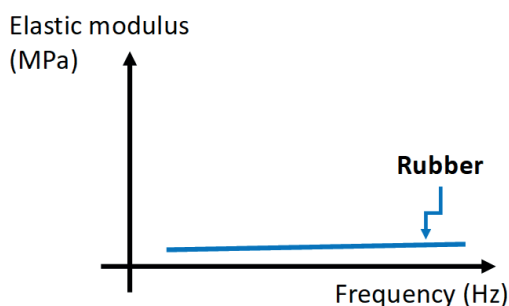
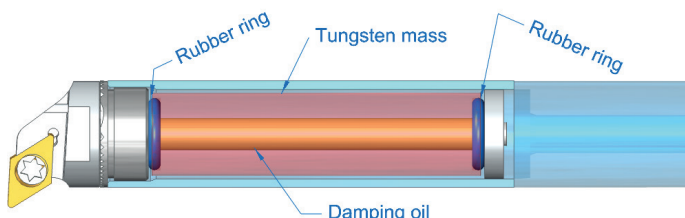

5A GENERAZIONE MAQ

Polimeri con rigidità dipendente dalla frequenza

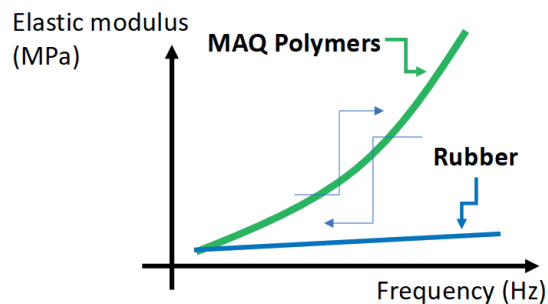
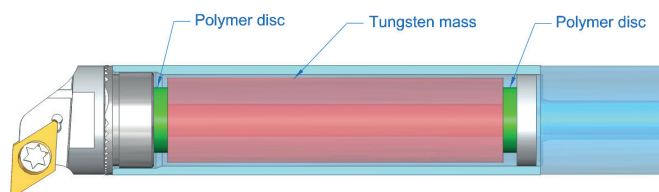

Table of Contents

Turning 3-6xD	4
Straight holder (3-6xD) with fixed cutter heads (Metric)	4
Straight holder (3-6xD) with fixed cutter heads (Inch)	6
Turning 6-9xD	7
Straight holder (6-9xD) with SL (Serration Lock) interface (Metric)	7
Straight holder (6-9xD) with SL (Serration Lock) interface (Inch)	8
Turning 8-12xD	9
Straight holder (8-12xD) with fixed cutter heads (Metric)	9
Straight holder (8-12xD) with fixed cutter heads (Inch)	10
Straight holder (8-12xD) with SL (Serration Lock) interface (Metric)	11
Straight holder (8-12xD) with SL (Serration Lock) interface (Inch)	12
Turning 11-15xD.....	13
Straight holder (11-15xD) with SL (Serration Lock) interface (Metric)	13
Straight holder (11-15xD) with SL (Serration Lock) interface (Inch)	14
Turning – Multitask with modular backends.	15
Standard: PSC32 (with SL interface and exchangeable heads).....	15
Standard: PSC40 (with SL interface and exchangeable heads).....	16
Standard: PSC50 (with SL interface and exchangeable heads).....	16
Standard: PSC63 (with SL interface and exchangeable heads).....	17
Standard: PSC80 (with SL interface and exchangeable heads).....	18
Standard: HSK63T (with SL interface and exchangeable heads)	19
Tools with KL interface	20
Burnishing	21
Diamond burnishing Right hand	21
End-effecters	22
SDUCR, SDUCL for DCMT Inserts	22
SDQCR for DCMT Inserts.....	23
SDXCR for DCMT Inserts	23
Back boring – B-SDUCR for DCMT Inserts.....	24
STFCR, STFCL for TCMT Inserts	25
STFPR for TPMT Inserts.....	26
SCLCR, SCLCL for CCMT Inserts	27
SVUCR, SVUCL for VCMT Inserts	28
Back boring – B-SVUCR for VCMT Inserts	29
PDUNR, PDUNL for DNMG Inserts	30
PTFNR, PTFNL for TNMG Inserts	30
PCLNR, PCLNL for CNMG Inserts.....	31
PWLNR, PWLNL for WNMG Inserts	31
End effecters - Threading	32
End effecters – Grooving	34
End effecters – SL blanks	35
SL blanks Left hand	35

SL blanks Right hand	35
Accessories	36
Modular fixtures	36
Reduction sleeves	37
Level Indicator/Digital protractor (angle inclinometer).....	39
Insert screws	39
Cutter head screws	40
Shims	40
Service kit for P clamp heads (includes level, shim, slot screw, spring)	41
Coolant adapters for steel bars	42
Coolant adapters for carbide bars	42
MAQ Master Inserts.....	43
Clamping of Turning tools	44

Turning 3-6xD

Straight holder (3-6xD) with fixed cutter heads (Metric)

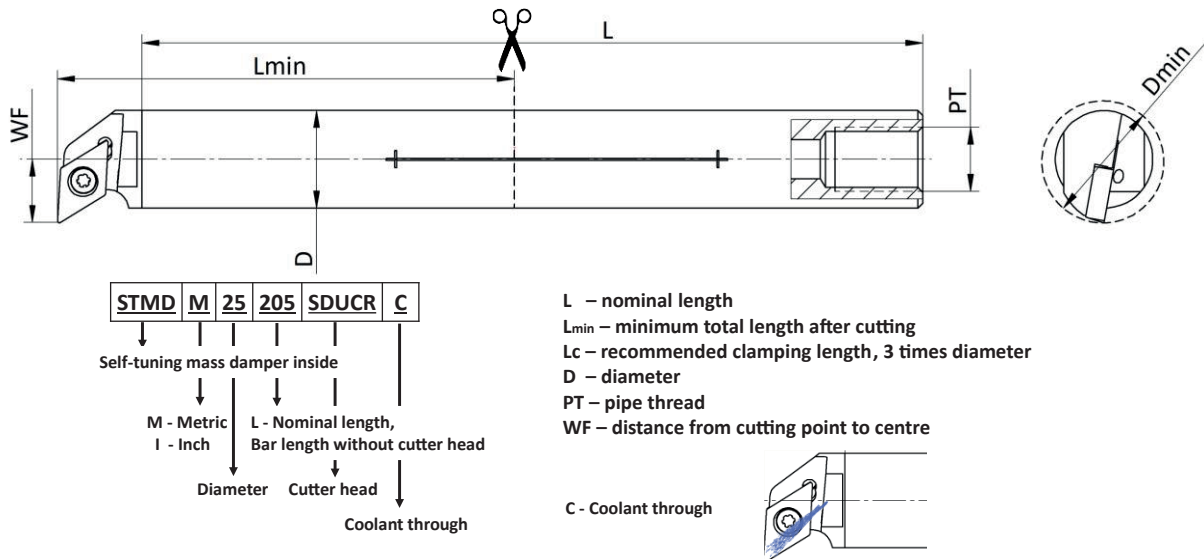

Standard: Metric (with fixed head SDUCR for DCMT insert)										
Part number	Type	Dmin (mm)	Workable length ^b (mm)	Lmin (mm)	Lc (mm)	WF (mm)	Master insert	Insert screw	PT	KG
300205	STMD M12-108 SDUCR C	16	36-72	72	36	9	DCMT 070204	IS M2.5x6.0	G ½	0.1
300176	STMD M16-138 SDUCR C	20	48-96	96	48	11	DCMT 070204	IS M2.5x6.0	G ¼	0.2
300177	STMD M20-160 SDUCR C	25	60-120	120	60	13	DCMT 11T304	IS M3.5x10.0	G ¼	0.4
300110	STMD M25-205 SDUCR C	32	75-150	155	75	17	DCMT 11T304	IS M3.5x10.0	G ¼	0.6
300178	STMD M32-256 SDUCR C	40	96-192	192	96	22	DCMT 11T304	IS M3.5x10.0	G ½	1.2
300179	STMD M40-320 SDUCR C	50	120-240	240	120	27	DCMT 11T304	IS M3.5x10.0	G ½	2.4

Standard: Metric (with fixed head SCLCR for CCMT insert)										
Part number	Type	Dmin (mm)	Workable length ^b (mm)	Lmin (mm)	Lc (mm)	WF (mm)	Master insert	Insert screw	PT	KG
300206	STMD M12-108 SCLCR C	16	36-72	72	36	8,5	CCMT 060204	IS M2.5x6.0	G ½	0.1
300186	STMD M16-138 SCLCR C	20	48-96	96	48	11	CCMT 060204	IS M2.5x6.0	G ¼	0.2
300188	STMD M20-160 SCLCR C	25	60-120	120	60	13	CCMT 09T304	IS M3.5x10.0	G ¼	0.4
300184	STMD M25-205 SCLCR C	32	75-150	155	75	17	CCMT 09T304	IS M3.5x10.0	G ¼	0.6
300183	STMD M32-256 SCLCR C	40	96-192	192	96	22	CCMT 09T304	IS M3.5x10.0	G ½	1.2
300181	STMD M40-320 SCLCR C	50	120-240	240	120	27	CCMT 09T304	IS M3.5x10.0	G ½	2.4

Standard: Metric (with fixed head STFCR for TCMT insert)										
Part number	Type	Dmin (mm)	Workable length ^b (mm)	Lmin (mm)	Lc (mm)	WF (mm)	Master insert	Insert screw	PT	KG
300207	STMD M12-108 STFCR C 0902	16	36-72	72	36	9	TCMT 090204	IS M2.2x5.0	G ½	0.1
300587	STMD M12-108 STFCR C 1102	16	36-72	72	36	9	TCMT 110204	IS M2.5x6.0	G ½	0.1
300187	STMD M16-138 STFCR C 0902	20	48-96	96	48	11	TCMT 090204	IS M2.2x5.0	G ¼	0.2
300588	STMD M16-138 STFCR C 1102	20	48-96	96	48	11	TCMT 110204	IS M2.5x6.0	G ¼	0.2
300589	STMD M20-160 STFCR C 1102	25	60-120	120	60	13	TCMT 110204	IS M2.5x8.0	G ¼	0.4
300189	STMD M20-160 STFCR C 1103	25	60-120	120	60	13	TCMT 110304	IS M2.5x8.0	G ¼	0.4
300590	STMD M25-205 STFCR C 1102	32	75-150	155	75	17	TCMT 110204	IS M2.5x8.0	G ¼	0.6
300185	STMD M25-205 STFCR C 1103	32	75-150	155	75	17	TCMT 110304	IS M2.5x8.0	G ¼	0.6
300180	STMD M32-256 STFCR C 16T3	40	96-192	192	96	22	TCMT 16T304	IS M3.5x10.0	G ½	1.2
300182	STMD M40-320 STFCR C 16T3	50	120-240	240	120	27	TCMT 16T304	IS M3.5x10.0	G ½	2.4

b – measured from the cutting edge to the clamping

Standard: Metric (with fixed head SDUCL for DCMT insert)										
Part number	Type	Dmin (mm)	Workable length ^b (mm)	Lmin (mm)	Lc (mm)	WF (mm)	Master insert	Insert screw	PT	
300405	STMD M12-108 SDUCL C	16	36-72	72	36	9	DCMT 070204	IS M2.5x6.0	G ½	0.1
300406	STMD M16-138 SDUCL C	20	48-96	96	48	11	DCMT 070204	IS M2.5x6.0	G ¼	0.2
300407	STMD M20-160 SDUCL C	25	60-120	120	60	13	DCMT 11T304	IS M3.5x10.0	G ¼	0.4
300408	STMD M25-205 SDUCL C	32	75-150	155	75	17	DCMT 11T304	IS M3.5x10.0	G ¼	0.6
300409	STMD M32-256 SDUCL C	40	96-192	192	96	22	DCMT 11T304	IS M3.5x10.0	G ½	1.2
300410	STMD M40-320 SDUCL C	50	120-240	240	120	27	DCMT 11T304	IS M3.5x10.0	G ½	2.4

Standard: Metric (with fixed head SCLCL for CCMT insert)										
300411	STMD M12-108 SCLCL C	16	36-72	72	36	8,5	CCMT 060204	IS M2.5x6.0	G ½	0.1
300412	STMD M16-138 SCLCL C	20	48-96	96	48	11	CCMT 060204	IS M2.5x6.0	G ¼	0.2
300413	STMD M20-160 SCLCL C	25	60-120	120	60	13	CCMT 09T304	IS M3.5x10.0	G ¼	0.4
300414	STMD M25-205 SCLCL C	32	75-150	155	75	17	CCMT 09T304	IS M3.5x10.0	G ¼	0.6
300415	STMD M32-256 SCLCL C	40	96-192	192	96	22	CCMT 09T304	IS M3.5x10.0	G ½	1.2
300416	STMD M40-320 SCLCL C	50	120-240	240	120	27	CCMT 09T304	IS M3.5x10.0	G ½	2.4

Standard: Metric (with fixed head STFCL for TCMT insert)										
300591	STMD M12-108 STFCL C 1102	16	36-72	72	36	9	TCMT 110204	IS M2.5x6.0	G ½	0.1
300592	STMD M16-138 STFCL C 1102	20	48-96	96	48	11	TCMT 110204	IS M2.5x6.0	G ¼	0.2
300593	STMD M20-160 STFCL C 1102	25	60-120	120	60	13	TCMT 110204	IS M2.5x8.0	G ¼	0.4
300594	STMD M25-205 STFCL C 1102	32	75-150	155	75	17	TCMT 110204	IS M2.5x8.0	G ¼	0.6
300595	STMD M32-256 STFCL C 16T3	40	96-192	192	96	22	TCMT 16T304	IS M3.5x10.0	G ½	1.2
300596	STMD M40-320 STFCL C 16T3	50	120-240	240	120	27	TCMT 16T304	IS M3.5x10.0	G ½	2.4

b – measured from the cutting edge to the clamping

Straight holder (3-6xD) with fixed cutter heads (Inch)

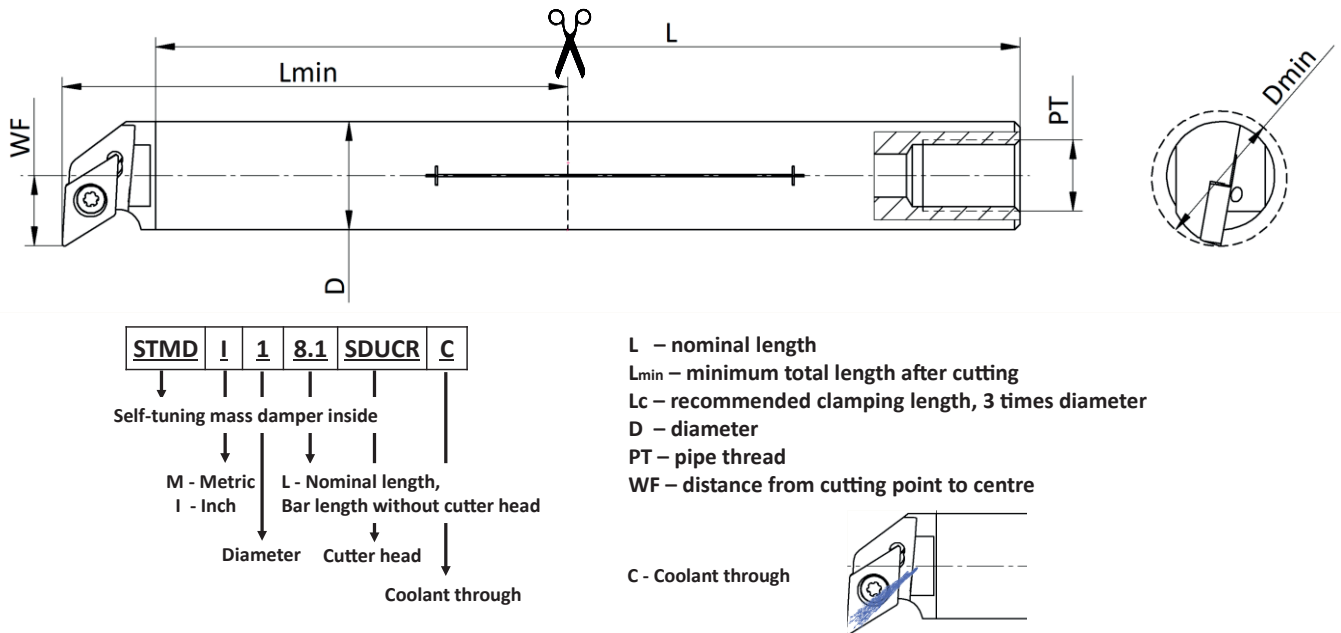

Standard: Inch (with fixed head SDUCR for DCMT insert)										
Part number	Art. Nr	Dmin (inch)	Workable length ^b (inch)	Lmin (inch)	Lc (inch)	WF (inch)	Master insert	Insert screw	PT	KG
300211	STMD I ½ -4.3 SDUCR C	0.63	1.500-3.000	2.8	1.4	0.35	DCMT 070204	IS M2.5x6.0	G ¼	0.1
300212	STMD I 5/8 – 5.4 SDUCR C	0.78	1.875-3.750	3.8	1.9	0.43	DCMT 070204	IS M2.5x6.0	G ¼	0.2
300213	STMD I ¾ - 6.3 SDUCR C	0.98	2.250-4.500	4.7	2.4	0.51	DCMT 11T304	IS M3.5x10.0	G ¼	0.4
300214	STMD I 1-8.1 SDUCR C	1.26	3.000-6.000	6.1	2.9	0.67	DCMT 11T304	IS M3.5x10.0	G ¼	0.6
300215	STMD I 1 ¼ -10.1 SDUCR C	1.57	3.750-7.500	7.6	3.8	0.86	DCMT 11T304	IS M3.5x10.0	G ½	1.2
300216	STMD I 1 ½-12.6 SDUCR C	1.96	4.500-9.000	9.4	4.7	1.06	DCMT 11T304	IS M3.5x10.0	G ½	2.4

Standard: Inch (with fixed head SCLCR for CCMT insert)										
Part number	Art. Nr	Dmin (inch)	Workable length ^b (inch)	Lmin (inch)	Lc (inch)	WF (inch)	Master insert	Insert screw	PT	KG
300217	STMD I ½ -4.3 SCLCR C	0.63	1.500-3.000	2.8	1.4	0.33	CCMT 060204	IS M2.5x6.0	G ¼	0.1
300218	STMD I 5/8 – 5.4 SCLCR C	0.78	1.875-3.750	3.8	1.9	0.43	CCMT 060204	IS M2.5x6.0	G ¼	0.2
300219	STMD I ¾ - 6.3 SCLCR C	0.98	2.250-4.500	4.7	2.4	0.51	CCMT 09T304	IS M3.5x10.0	G ¼	0.4
300220	STMD I 1-8.1 SCLCR C	1.26	3.000-6.000	6.1	2.9	0.67	CCMT 09T304	IS M3.5x10.0	G ¼	0.6
300221	STMD I 1 ¼ -10.1 SCLCR C	1.57	3.750-7.500	7.6	3.8	0.86	CCMT 09T304	IS M3.5x10.0	G ½	1.2
300222	STMD I 1 ½-12.6 SCLCR C	1.96	4.500-9.000	9.4	4.7	1.06	CCMT 09T304	IS M3.5x10.0	G ½	2.4

Standard: Inch (with fixed head STFCR for TCMT insert)										
Part number	Art. Nr	Dmin (inch)	Workable length ^b (inch)	Lmin (inch)	Lc (inch)	WF (inch)	Master insert	Insert screw	PT	KG
300223	STMD I ½ -4.3 STFCR C	0.63	1.500-3.000	2.8	1.4	0.35	TCMT 090204	IS M2.2x5.0	G ⅝	0.1
300224	STMD I 5/8 – 5.4 STFCR C	0.78	1.875-3.750	3.8	1.9	0.43	TCMT 090204	IS M2.2x5.0	G ¼	0.2
300225	STMD I ¾ - 6.3 STFCR C	0.98	2.250-4.500	4.7	2.4	0.51	TCMT 110304	IS M2.5x8.0	G ¼	0.4
300226	STMD I 1-8.1 STFCR C	1.26	3.000-6.000	6.1	2.9	0.67	TCMT 110304	IS M2.5x8.0	G ¼	0.6
300227	STMD I 1 ¼ -10.1 STFCR C	1.57	3.750-7.500	7.6	3.8	0.86	TCMT 16T304	IS M3.5x10.0	G ½	1.2
300228	STMD I 1 ½-12.6 STFCR C	1.96	4.500-9.000	9.4	4.7	1.06	TCMT 16T304	IS M3.5x10.0	G ½	2.4

b – measured from the cutting edge to the clamping

Turning 6-9xD

Straight holder (6-9xD) with SL (Serration Lock) interface (Metric)

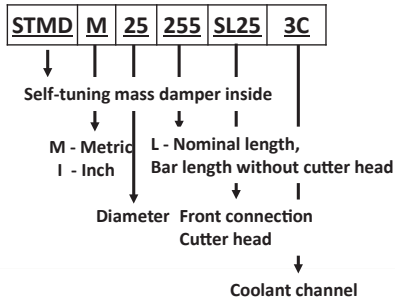
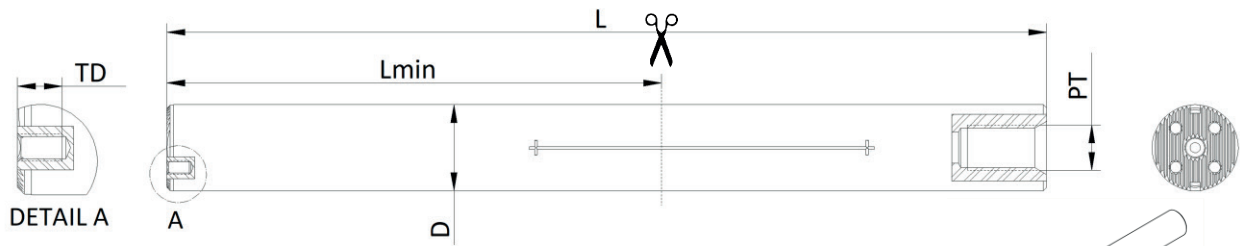

L – nominal length
 L_{min} – minimum total length after cutting
 L_c – recommended clamping length, 3 times diameter
 D – diameter
 PT – pipe thread
 TD – thread depth

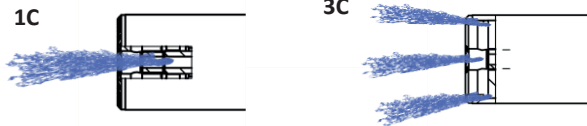

Standard: Metric (with SL interface and exchangeable heads)										
Part number	Type	Workable length ^b (mm)	D min (mm) ^g	Lmin (mm)	Lc (mm)	Screws	TD (mm)	PT	Material	KG
300001	STMD M12-144 SL12 3C	72-96	16	144	36	M2X8 or 14	5.5	G ½	S+C ^d	0.18
300004	STMD M16-170 SL16 3C	96-128	20	117	48	M3X8	5.5	G ¾	Steel	0.25
300005	STMD M20-200 SL20 3C	120-160	25	137	60	M3X8	5.5	G ¾	Steel	0.50
300006	STMD M25-255 SL25 3C	150-200	32	180	75	M4X9	6.5	G ¾	Steel	1.10
300008	STMD M32-320 SL32 3C	192-256	40	213	96	M5X12	10	G ½	Steel	2.10
300010	STMD M40-408 SL40 1C ^e	240-320	50	260	120	M6X14	10	G ½	Steel	3.9
300240	STMD M40-408 SL40 3C	240-320	50	260	120	M6X14	10	G ½	Steel	3.9
300012	STMD M50-518-SL40 1C	300-400	60	324	150	M6X14	10	G ¾	Steel	8.0
300013	STMD M50-518-SL50 1C ^e	300-400	NA	322	150	M8X14	12	G ¾	Steel	8.0
300015	STMD M60-628-SL40 1C	360-480	70	424	180	M6X14	10	G ¾	Steel	13.6
300016	STMD M60-628-SL60 1C ^e	360-480	NA	422	180	M8X14	12	G ¾	Steel	13.6
300585	STMD M80-880-SL40 1C ^e	480-640	90	546	240	M6X14	10	G 1 ¼	Steel	33.0

b – measured from the cutting edge to the clamping.
 d – Carbide back end joined with steel
 e – only on order and with a longer lead-time,
 g - estimated with using standard SDUCR cutter heads from MAQ.

Straight holder (6-9xD) with SL (Serration Lock) interface (Inch)

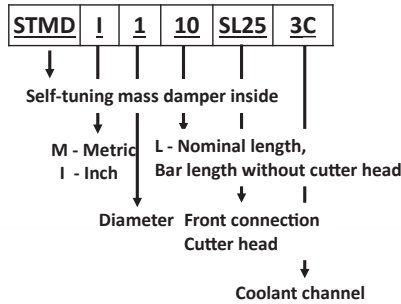
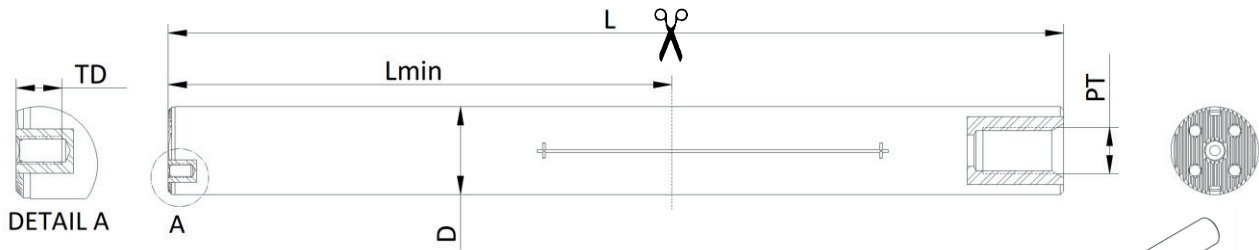

L – nominal length
L_{min} – minimum total length after cutting
L_c – recommended clamping length, 3 times diameter
D – diameter
PT – pipe thread
TD – thread depth



Standard: Inch (with SL interface and exchangeable heads)										
Part number	Type	Workable length ^b (inch)	D min (inch) ^g	Lmin (inch)	Lc (inch)	Screws	TD (mm)	PT	Material	KG
300040	STMD I 1/2-5.7 SL12 3C	3.000–4.000	0.630	5.7	1.41	M2X8 or 14	5.5	G 3/8	S+C ^d	0.18
300041	STMD I 5/8-6.7 SL16 3C	3.750–5.000	0.787	4.6	1.88	M3X8	5.5	G 3/8	Steel	0.25
300042	STMD I 3/4-7.9 SL20 3C	4.500–6.000	0.984	5.4	2.25	M3X8	5.5	G 3/8	Steel	0.50
300043	STMD I 1-10 SL25 3C	6.000–8.000	1.260	7.1	3.00	M4X9	6.5	G 3/8	Steel	1.10
300044	STMD I 1 1/4-12.6 SL32 3C	7.500–10.000	1.575	8.4	3.75	M5X12	10	G 1/2	Steel	2.10
300255	STMD I 1 1/2-16.0 SL40 1C ^e	9.000–12.000	1.969	10.2	4.72	M6X14	10	G 1/2	Steel	3.90
300045	STMD I 1 1/2-16.0-SL40 3C	9.000–12.000	1.969	10.2	4.72	M6X14	10	G 1/2	Steel	3.90
300046	STMD I 2-20.4-SL40 1C	12.000–16.000	2.362	12.7	5.90	M6X14	10	G 3/4	Steel	8.00
300047	STMD I 2-20.4-SL50 1C ^e	12.000–16.000	NA	12.7	5.90	M8X14	10	G 3/4	Steel	8.00
300048	STMD I 2 1/2-24.7-SL40 1C	15.000–20.000	2.756	16.7	7.10	M6X14	12	G 3/4	Steel	13.60
300049	STMD I 2 1/2-24.7-SL60 1C ^e	15.000–20.000	NA	16.7	7.10	M8X14	10	G 3/4	Steel	13.60
300586	STMD I 3-34.6-SL40 1C ^e	18.900–25.200	3.543	21.5	9.40	M6X14	12	G 1 1/4	Steel	30.0

b – measured from the cutting edge to the clamping.
d – Carbide back end joined with steel
e – only on order and with a longer lead-time,
g - estimated with using standard SDUCR cutter heads from MAQ.

Turning 8-12xD

Straight holder (8-12xD) with fixed cutter heads (Metric)

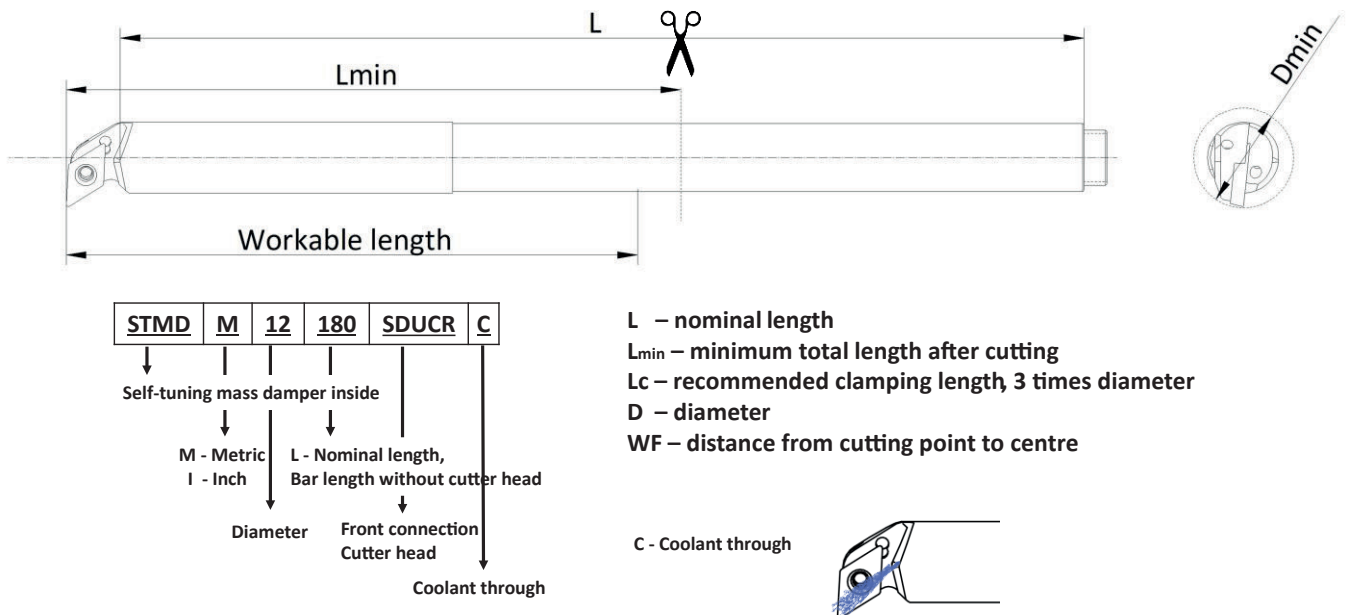

Standard: Metric (with fixed head)											
Part number	Type	Workable length ^b (mm)	Dmin (mm)	Lmin ^a (mm)	Lc (mm)	WF ^c (mm)	PT	Master insert	Insert screw	Material	KG
300680	STMD M06-90 SCLCR	42-66	8	96	18	3.5	NA	CCMT 040102	IS M2.0x4.0	S+C ^d	0.04
300565	STMD M08-120 SDQCR C	56-88	11	130	24	6	M7x0.5	DCMT 070204	IS M2.5x4.5	S+C ^d	0.15
300567	STMD M08-120 SDQCL C	56-88	11	130	24	6	M7x0.5	DCMT 070204	IS M2.5x4.5	S+C ^d	0.15
300310	STMD M08-120 SCLCR C	56-88	10	128	24	5	M7x0.5	CCMT 060204	IS M2.5x4.5	S+C ^d	0.15
300568	STMD M08-120 SCLCL C	56-88	10	128	24	5	M7x0.5	CCMT 060204	IS M2.5x4.5	S+C ^d	0.15
300386	STMD M08-120 STUBR C	56-88	10	127	24	5	M7x0.5	TBGT 060104	IS M2.0x4.0	S+C ^d	0.15
300569	STMD M08-120 STUBL C	56-88	10	127	24	5	M7x0.5	TBGT 060104	IS M2.0x4.0	S+C ^d	0.15
300389	STMD M10-150 SDUCR C	70-110	15	160	30	9	M9x0.75	DCMT 070204	IS M2.5x6.0	S+C ^d	0.20
300570	STMD M10-150 SDUCL C	70-110	15	160	30	9	M9x0.75	DCMT 070204	IS M2.5x6.0	S+C ^d	0.20
300390	STMD M10-150 SCLCR C	70-110	12	161	30	6.1	M9x0.75	CCMT 060204	IS M2.5x6.0	S+C ^d	0.20
300571	STMD M10-150 SCLCL C	70-110	12	161	30	6.1	M9x0.75	CCMT 060204	IS M2.5x6.0	S+C ^d	0.20
300391	STMD M10-150 STFCR C	70-110	13	163	30	6.8	M9x0.75	TCMT 090204	IS M2.2x5.0	S+C ^d	0.20
300572	STMD M10-150 STFCL C	70-110	13	163	30	6.8	M9x0.75	TCMT 090204	IS M2.2x5.0	S+C ^d	0.20
300098	STMD M12-180 SDUCR C	84-132	16	179	36	8.9	G ½	DCMT 070204	IS M2.5x6.0	S+C ^d	0.30
300573	STMD M12-180 SDUCL C	84-132	16	179	36	8.9	G ½	DCMT 070204	IS M2.5x6.0	S+C ^d	0.30
300099	STMD M12-180 SCLCR C	84-132	16	179	36	8.5	G ½	CCMT 060204	IS M2.5x6.0	S+C ^d	0.30
300574	STMD M12-180 SCLCL C	84-132	16	179	36	8.5	G ½	CCMT 060204	IS M2.5x6.0	S+C ^d	0.30
300100	STMD M12-180 STFCR C	84-132	16	179	36	9	G ½	TCMT 090204	IS M2.2x5.0	S+C ^d	0.30
300575	STMD M12-180 STFCL C	84-132	16	179	36	9	G ½	TCMT 090204	IS M2.2x5.0	S+C ^d	0.30
301215	STMD M12-180 SVJCR C	84-132	14	179	36	7	G ½	VCMT 080204	IS M2.0x4.0	S+C ^d	0.30

a – total length to the cutting point
b – measured from the cutting edge to the clamping.
c – distance from cutting point to centre with master insert.
d – Carbide back end joined with steel

Straight holder (8-12xD) with fixed cutter heads (Inch)

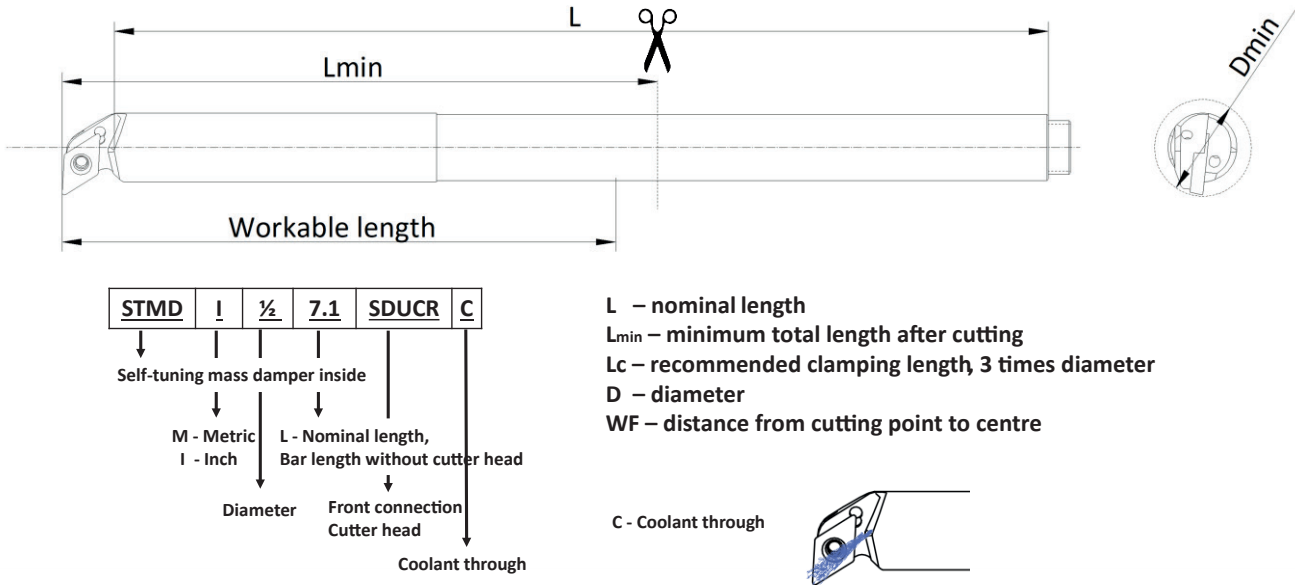

Standard: Inch (with fixed head)											
Part number	Type	Workable length ^b (inch)	Dmin (inch)	Lmin ^a (inch)	Lc (inch)	WF ^c (inch)	PT	Master insert	Insert screw	Material	KG
300681	STMD I 1/4-3.5 SCLCR	1.653-2.598	0.315	3.779	0.708	0.138	NA	CCMT 040102	IS M2.0x4.0	S+C ^d	0.04
300566	STMD I 5/16-4.7 SDQCR C	2.204-3.464	0.43	5.12	0.94	0.24	M7x0.5	DCMT 070204	IS M2.5x4.5	S+C ^d	0.15
300576	STMD I 5/16-4.7 SDQCL C	2.204-3.464	0.43	5.12	0.94	0.24	M7x0.5	DCMT 070204	IS M2.5x4.5	S+C ^d	0.15
300387	STMD I 5/16-4.7 SCLCR C	2.204-3.464	0.39	5.04	0.94	0.20	M7x0.5	CCMT 060204	IS M2.5x4.5	S+C ^d	0.15
300577	STMD I 5/16-4.7 SCLCL C	2.204-3.464	0.39	5.04	0.94	0.20	M7x0.5	CCMT 060204	IS M2.5x4.5	S+C ^d	0.15
300388	STMD I 5/16-4.7 STUBR C	2.204-3.464	0.39	5.00	0.94	0.20	M7x0.5	TBGT 060104	IS M2.0x4.0	S+C ^d	0.15
300578	STMD I 5/16-4.7 STUBL C	2.204-3.464	0.39	5.00	0.94	0.20	M7x0.5	TBGT 060104	IS M2.0x4.0	S+C ^d	0.15
300392	STMD I 3/8-5.9 SDUCR C	2.625-4.125	0.59	6.30	1.18	0.35	M9x0.75	DCMT 070204	IS M2.5x6.0	S+C ^d	0.20
300579	STMD I 3/8-5.9 SDUCL C	2.625-4.125	0.59	6.30	1.18	0.35	M9x0.75	DCMT 070204	IS M2.5x6.0	S+C ^d	0.20
300393	STMD I 3/8-5.9 SCLCR C	2.625-4.125	0.47	6.34	1.18	0.24	M9x0.75	CCMT 060204	IS M2.5x6.0	S+C ^d	0.20
300580	STMD I 3/8-5.9 SCLCL C	2.625-4.125	0.47	6.34	1.18	0.24	M9x0.75	CCMT 060204	IS M2.5x6.0	S+C ^d	0.20
300394	STMD I 3/8-5.9 STFRC C	2.625-4.125	0.51	6.42	1.18	0.27	M9x0.75	TCMT 090204	IS M2.2x5.0	S+C ^d	0.20
300581	STMD I 3/8-5.9 STFCL C	2.625-4.125	0.51	6.42	1.18	0.27	M9x0.75	TCMT 090204	IS M2.2x5.0	S+C ^d	0.20
300153	STMD I 1/2 -7.1 SDUCR C	3.500-5.500	0.63	7.05	1.42	0.35	G 1/2	DCMT 070204	IS M2.5x6.0	S+C ^d	0.30
300582	STMD I 1/2 -7.1 SDUCL C	3.500-5.500	0.63	7.05	1.42	0.35	G 1/2	DCMT 070204	IS M2.5x6.0	S+C ^d	0.30
300154	STMD I 1/2 -7.1 SCLCR C	3.500-5.500	0.63	7.05	1.42	0.33	G 1/2	CCMT 060204	IS M2.5x6.0	S+C ^d	0.30
300583	STMD I 1/2 -7.1 SCLCL C	3.500-5.500	0.63	7.05	1.42	0.33	G 1/2	CCMT 060204	IS M2.5x6.0	S+C ^d	0.30
300155	STMD I 1/2 -7.1 STFRC C	3.500-5.500	0.63	7.05	1.42	0.35	G 1/2	TCMT 090204	IS M2.2x5.0	S+C ^d	0.30
300584	STMD I 1/2 -7.1 STFCL C	3.500-5.500	0.63	7.05	1.42	0.35	G 1/2	TCMT 090204	IS M2.2x5.0	S+C ^d	0.30
301216	STMD I 1/2 -7.1 SVJCR C	3.500-5.500	0.55	7.05	1.42	0.28	G 1/2	VCMT 080204	IS M2.0x4.0	S+C ^d	0.30

a – total length to the cutting point
b – measured from the cutting edge to the clamping.
c – distance from cutting point to centre with master insert.
d – Carbide back end joined with steel

Straight holder (8-12xD) with SL (Serration Lock) interface (Metric)

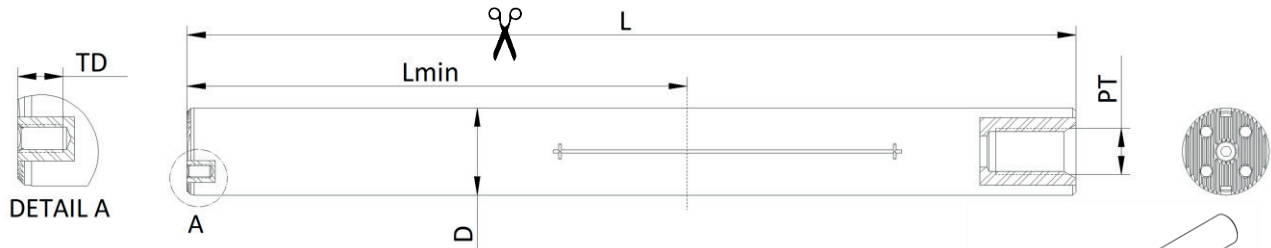

STMD	M	25	330	SL25	3C
------	---	----	-----	------	----

Self-tuning mass damper inside
 M - Metric
 I - Inch
 L - Nominal length,
 Bar length without cutter head
 Diameter Front connection
 Cutter head
 Coolant channel

L – nominal length
 L_{min} – minimum total length after cutting
 L_c – recommended clamping length, 3 times diameter
 D – diameter
 PT – pipe thread
 TD – thread depth

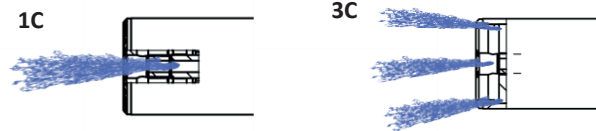

Standard: Metric (with SL interface and exchangeable heads)										
Part number	Type	Workable length ^b (mm)	D min (mm) ^g	Lmin (mm)	Lc (mm)	Screws	TD (mm)	PT	Material	KG
300017	STMD M16-204 SL16 3C	128-176	20	204	48	M3X8	5.5	G ½	S+C ^d	0.50
300018	STMD M20-260 SL20 3C	160-220	25	260	60	M3X8	5.5	G ¼	S+C ^d	1.00
300019	STMD M25-330 SL25 3C	200-275	32	255	75	M4X9	6.5	G ¼	Steel	1.70
300020	STMD M32-416 SL32 3C	256-352	40	309	96	M5X12	10	G ½	Steel	3.50
300241	STMD M40-528 SL40 1C ^e	320-440	50	312	120	M6X14	10	G ½	Steel	5.00
300021	STMD M40-528 SL40 3C	320-440	50	312	120	M6X14	10	G ½	Steel	5.00
300022	STMD M50-660-SL40 1C	400-550	60	384	150	M6X14	10	G ¾	Steel	9.40
300023	STMD M50-660-SL50 1C ^e	400-550	NA	382	150	M8X14	12	G ¾	Steel	9.40
300024	STMD M60-808-SL40 1C	480-660	70	484	180	M6X14	10	G ¾	Steel	16.4
300025	STMD M60-808-SL60 1C ^e	480-660	NA	482	180	M8X14	12	G ¾	Steel	16.4
300242	STMD M80-1200-SL40 1C ^e	640-880	90	645	240	M6X14	10	G 1 ¼	Steel	42.0

b – measured from the cutting edge to the clamping.
 d – Carbide back end joined with steel
 e – only on order and with a longer lead time
 g- estimated with using standard SDUCR cutter heads from MAQ.

Straight holder (8-12xD) with SL (Serration Lock) interface (Inch)

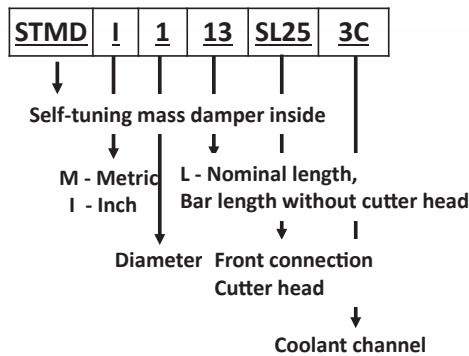
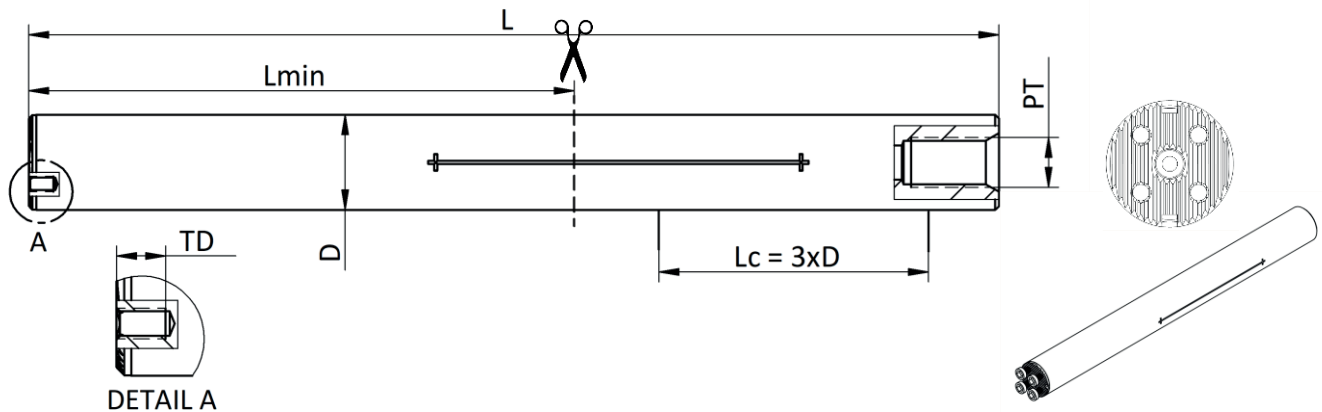

L – nominal length
L_{min} – minimum total length after cutting
L_c – recommended clamping length, 3 times diameter
D – diameter
PT – pipe thread
TD – thread depth

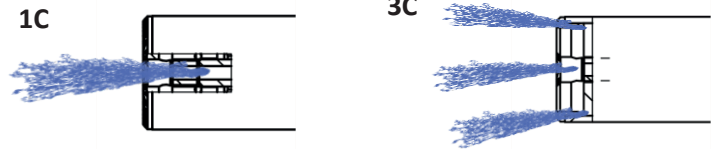

Standard: Inch (with exchangeable heads)										
Part number	Type	Workable length ^b (inch)	D _{min} (inch) ^g	L _{min} ^a (inch)	L _c (inch)	Screws	TD (mm)	PT	Material	KG
300050	STMD I 5/8-8.0 SL16 3C	5.000-6.875	0.787	8.0	1.88	M3X8	5.5	G 3/8	S+C ^d	0.50
300051	STMD I 3/4-10.3 SL20 3C	6.000-8.250	0.984	10.2	2.25	M3X8	5.5	G 3/4	S+C ^d	1.00
300052	STMD I 1-13 SL25 3C	8.000-11.000	1.260	8.1	3.00	M4X9	6.5	G 3/4	Steel	1.70
300053	STMD I 1 1/4-16.4 SL32 3C	10.000-13.750	1.575	12.2	3.75	M5X14	10	G 1/2	Steel	3.50
300256	STMD I 1 1/2-20.8 SL40 1C ^e	12.000-16.500	1.969	12.3	4.72	M6X14	10	G 1/2	Steel	5.00
300054	STMD I 1 1/2-20.8 SL40 3C	12.000-16.500	1.969	12.3	4.72	M6X14	10	G 3/4	Steel	5.00
300055	STMD I 2-26.0-SL40 1C	16.000-22.000	2.362	15.0	5.90	M6X14	10	G 3/4	Steel	9.40
300056	STMD I 2-26.0-SL50 1C ^e	16.000-22.000	NA	15.0	5.90	M8X14	10	G 3/4	Steel	9.40
300057	STMD I 2 1/2-31.8-SL40 1C	20.000-27.500	2.756	19.1	7.10	M6X14	12	G 3/4	Steel	16.40
300058	STMD I 2 1/2-31.8-SL60 1C ^e	20.000-27.500	NA	19.1	7.10	M8X14	10	G 3/4	Steel	16.40
300470	STMD I 3-47-SL40 1C ^e	25.000-34.600	3.543	25.4	9.40	M6X14	12	G 1 1/4	Steel	45.00

<p> ^b – measured from the cutting edge to the clamping. ^d – Carbide back end joined with steel ^e – only on order and with a longer lead-time, ^g - estimated with using standard SDUCR cutter heads from MAQ. </p>
--

Turning 11-15xD

Straight holder (11-15xD) with SL (Serration Lock) interface (Metric)

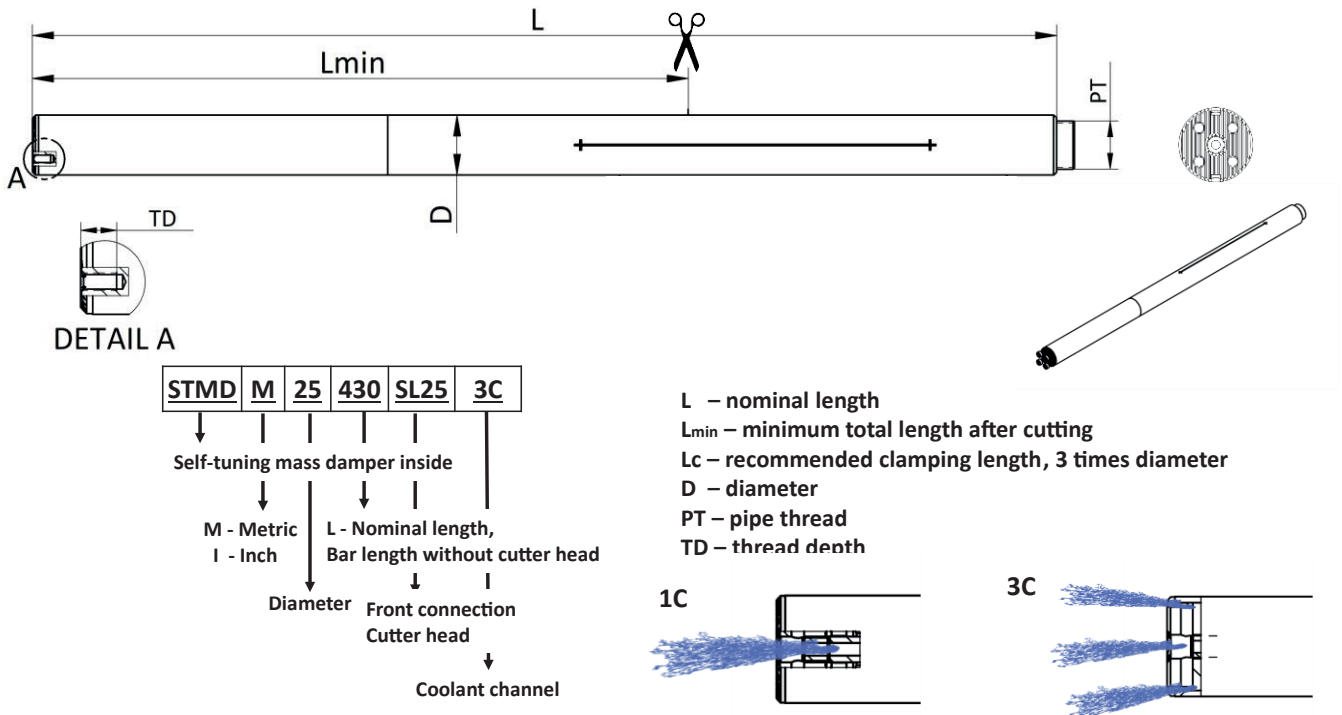

Standard: Metric (with SL interface and exchangeable heads)										
Part number	Type	Workable length ^b (mm)	D min (mm) ^g	Lmin (mm)	Lc (mm)	Screws	TD (mm)	PT	Material	KG
300089	STMD M16-268 SL16 3C	176-240	20	268	48	M3X8	5.5	G ½	S+C ^d	0.75
300090	STMD M20-340 SL20 3C	220-300	25	340	60	M3X8	5.5	G ¼	S+C ^d	1.50
300091	STMD M25-430 SL25 3C	275-375	32	430	75	M4X9	6.5	G ¼	S+C ^d	3.20
300085	STMD M32-544 SL32 3C	352-480	40	544	96	M5X12	10	G ¼	S+C ^d	6.40
300309	STMD M40-688 SL40 1C	440-600	50	688	120	M6x14	10	M36x1	S+C ^d	9.40
300093	STMD M40-688 SL40 3C	440-600	50	688	120	M6x14	10	M36x1	S+C ^d	9.40
300094	STMD M50-861-SL40 1C	550-750	60	861	150	M6X14	10	M42x1	S+C ^d	18.6
300095	STMD M50-861-SL50 1C	550-750	NA	861	150	M6X14	10	M42x1	S+C ^d	18.6
300096	STMD M60-1040-SL40 1C ^e	660-900	70	1040	180	M6x14	10	M52x1	S+C ^d	34.4
300097	STMD M60-1040-SL60 1C ^e	660-900	NA	1040	180	M6x14	10	M52x1	S+C ^d	34.4

<p>b – measured from the cutting edge to the clamping. d – Carbide back end joined with steel e – only on order and with a longer lead-time, g - estimated with using standard SDUCR cutter heads from MAQ.</p>
--

Straight holder (11-15xD) with SL (Serration Lock) interface (Inch)

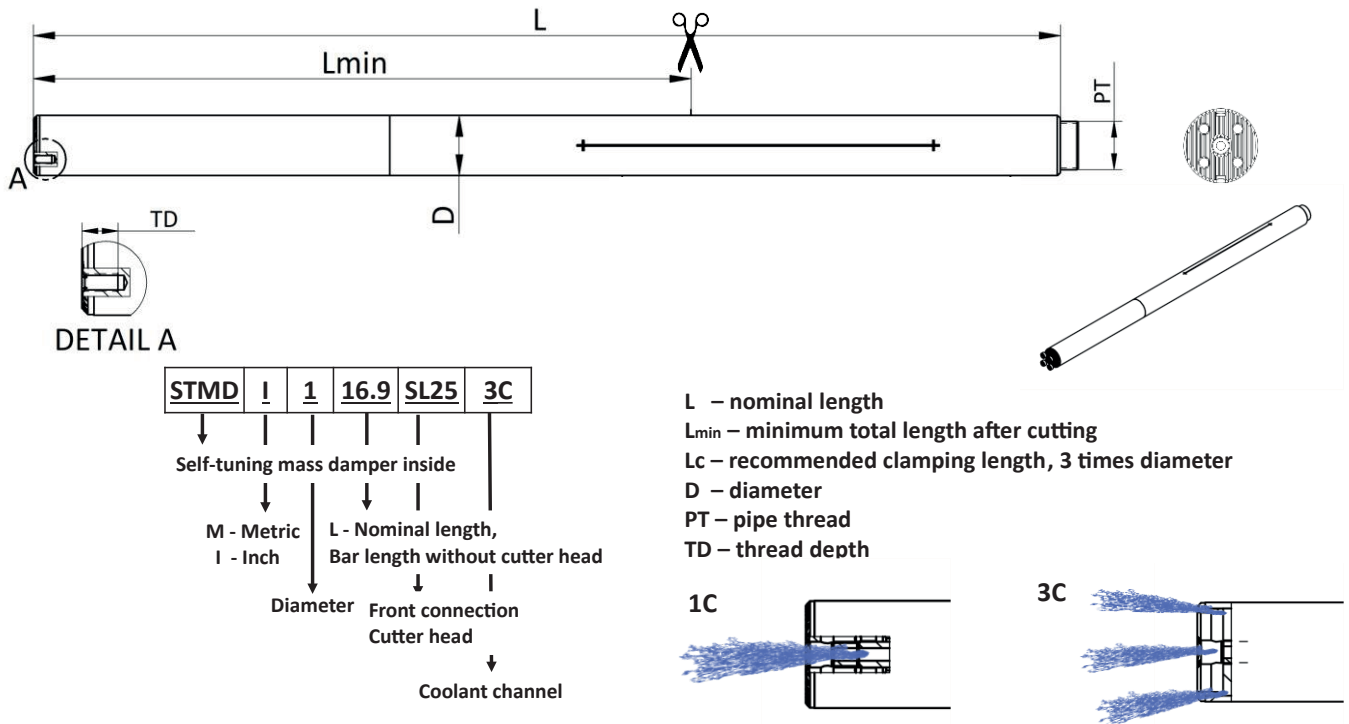

Standard: Inch (with SL interface and exchangeable heads)										
Part number	Type	Workable length ^b (inch)	D _{min} (inch) ^g	L _{min} (inch)	L _c (inch)	Screws	PT	TD (mm)	Material	KG
300159	STMD I 5/8-10.6 SL16 3C	6.875-9.375	0.787	10.6	1.88	M3X8	G ½	5.5	S+C ^d	0.75
300160	STMD I 3/4-13.4 SL20 3C	8.250-11.250	0.984	13.4	2.25	M3X8	G ¼ ²	5.5	S+C ^d	1.50
300161	STMD I 1-16.9 SL25 3C	11.000-15.000	1.260	16.9	3.00	M4X9	G ¼ ³	6.5	S+C ^d	3.20
300162	STMD I 1 1/4-21.4 SL32 3C	13.750-18.750	1.575	21.4	3.75	M5X14	G ¼ ⁴	10	S+C ^d	6.40
300397	STMD I 1 1/2-27.1 SL40 1C ^e	16.500-22.500	1.969	27.1	4.50	M6x14	M36x1	10	S+C ^d	9.40
300396	STMD I 1 1/2-27.1 SL40 3C ^e	16.500-22.500	1.969	27.1	4.50	M6x14	M36x1	10	S+C ^d	9.40
300398	STMD I 2-33.9-SL40 1C ^e	22.000-30.000	2.362	33.9	6.00	M6X14	M42x1	10	S+C ^d	18.6
300400	STMD I 2-33.9-SL50 1C ^e	22.000-30.000	NA	33.9	6.00	M8X14	M42x1	10	S+C ^d	18.6
300399	STMD I 2 1/2-40.9-SL40 1C ^e	27.500- 37.500	2.756	40.9	7.50	M6x14	M52x1	10	S+C ^d	34.4
300401	STMD I 2 1/2-40.9-SL60 1C ^e	27.500- 37.500	NA	40.9	7.50	M8x14	M52x1	10	S+C ^d	34.4

b – measured from the cutting edge to the clamping.
 d – Carbide back end joined with steel
 e – only on order and with a longer lead-time,
 g - estimated with using standard SDUCR cutter heads from MAQ.

Turning – Multitask with modular backends.

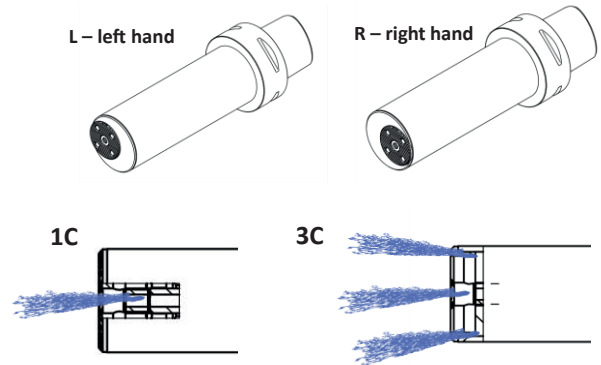
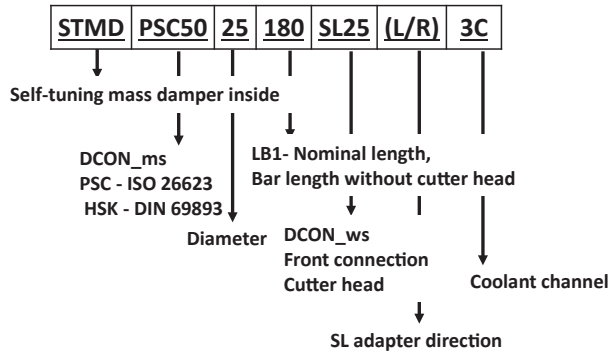
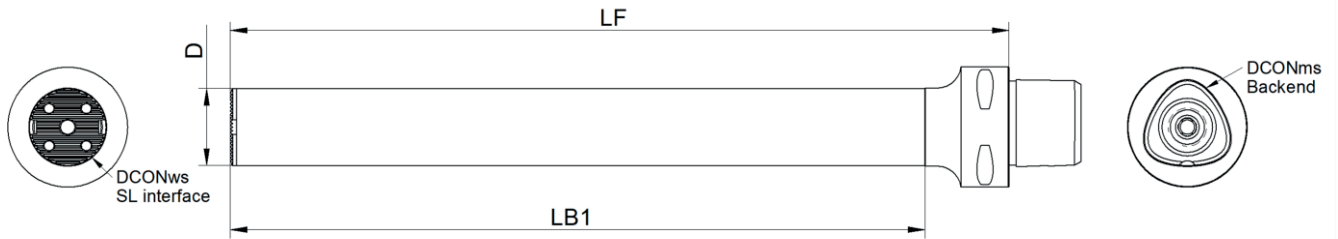

Standard: PSC32 (with SL interface and exchangeable heads)

Standard: PSC32 (with SL interface and exchangeable heads)										
Part number	Type	Backend	D (mm)	Dmin (mm) ^d	LF (mm)	LB1 (mm)	Screws	Material		
300476	STMD PSC32 16-064 SL16 3C	PSC32	16	20	99	64	M3X8	Steel	0.3	
300477	STMD PSC32 16-096 SL16 3C	PSC32	16	20	131	96	M3X8	Steel	0.3	
300478	STMD PSC32 20-090 SL20 3C	PSC32	20	25	125	90	M3X8	Steel	0.3	
300479	STMD PSC32 20-130 SL20 3C	PSC32	20	25	165	130	M3X8	Steel	0.4	
300480	STMD PSC32 25-130 SL25 3C	PSC32	25	32	165	130	M4X9	Steel	0.6	
300481	STMD PSC32 25-180 SL25 3C	PSC32	25	32	215	180	M4X9	Steel	0.8	
300482	STMD PSC32 25-230 SL25 3C	PSC32	25	32	265	230	M4X9	Steel	1.0	
300483	STMD PSC32 32-170 SL32 3C	PSC32	32	40	205	170	M5X12	Steel	1.8	
300484	STMD PSC32 32-230 SL32 3C	PSC32	32	40	265	230	M5X12	Steel	2.4	

^d - estimated with using standard SDUCR cutter heads from MAQ.

Standard: PSC40 (with SL interface and exchangeable heads)

Standard: PSC40 (with SL interface and exchangeable heads)									
Part number	Type	Backend	D (mm)	Dmin (mm) ^d	LF (mm)	LB1 (mm)	Screws	Material	
300485	STMD PSC40 16-064 SL16 3C	PSC40	16	20	100	64	M3X8	Steel	0.4
300486	STMD PSC40 16-096 SL16 3C	PSC40	16	20	132	96	M3X8	Steel	0.5
300487	STMD PSC40 20-090 SL20 3C	PSC40	20	25	126	90	M3X8	Steel	0.5
300488	STMD PSC40 20-130 SL20 3C	PSC40	20	25	166	130	M3X8	Steel	0.7
300489	STMD PSC40 25-130 SL25 3C	PSC40	25	32	167	130	M4X9	Steel	0.8
300490	STMD PSC40 25-180 SL25 3C	PSC40	25	32	216	180	M4X9	Steel	0.9
300491	STMD PSC40 25-230 SL25 3C	PSC40	25	32	266	230	M4X9	Steel	1.2
300492	STMD PSC40 32-170 SL32 3C	PSC40	32	40	206	170	M5X12	Steel	1.5
300493	STMD PSC40 32-230 SL32 3C	PSC40	32	40	266	230	M5X12	Steel	2.0
300494	STMD PSC40 32-294 SL32 3C	PSC40	32	40	330	294	M5X12	Steel	2.6
300495	STMD PSC40 40-210 SL40 3C	PSC40	40	50	246	210	M6X14	Steel	1.7
300496	STMD PSC40 40-290 SL40 3C	PSC40	40	50	326	290	M6x14	Steel	3.4

d - estimated with using standard SDUCR cutter heads from MAQ.

Standard: PSC50 (with SL interface and exchangeable heads)

Standard: PSC50 (with SL interface and exchangeable heads)									
Part number	Type	Backend	D (mm)	Dmin (mm) ^d	LF (mm)	LB1 (mm)	Screws	Material	
300497	STMD PSC50 16-064 SL16 3C	PSC50	16	20	99	64	M3X8	Steel	0.5
300498	STMD PSC50 16-096 SL16 3C	PSC50	16	20	131	96	M3X8	Steel	0.7
300499	STMD PSC50 20-090 SL20 3C	PSC50	20	20	131	96	M3X8	Steel	0.7
300500	STMD PSC50 20-130 SL20 3C	PSC50	20	25	165	130	M3X8	Steel	0.9
300501	STMD PSC50 25-130 SL25 3C	PSC50	25	32	165	130	M4X9	Steel	1.0
300462	STMD PSC50 25-180 SL25 3C	PSC50	25	32	215	180	M4X9	Steel	1.2
300463	STMD PSC50 25-230 SL25 3C	PSC50	25	32	265	230	M4X9	Steel	1.4
300502	STMD PSC50 32-170 SL32 3C	PSC50	32	40	205	170	M5X12	Steel	1.4
300464	STMD PSC50 32-230 SL32 3C	PSC50	32	40	265	230	M5X12	Steel	1.8
300465	STMD PSC50 32-294 SL32 3C	PSC50	32	40	329	294	M5X12	Steel	2.4
300503	STMD PSC50 40-210 SL40 3C	PSC50	40	50	245	210	M6X14	Steel	2.2
300504	STMD PSC50 40-290 SL40 3C	PSC50	40	50	325	290	M6x14	Steel	3.6
300505	STMD PSC50 40-370 SL40 3C	PSC50	40	50	405	370	M6x14	Steel	4.2
301184	STMD PSC50 50-270 SL40 L 1C	PSC50	50	60	305	270	M6x14	Steel	5.2
301185	STMD PSC50 50-370 SL40 L 1C	PSC50	50	60	405	370	M6x14	Steel	7.1
301200	STMD PSC50 50-270 SL40 R 1C	PSC50	50	60	305	270	M6x14	Steel	5.2
301201	STMD PSC50 50-370 SL40 R 1C	PSC50	50	60	405	370	M6x14	Steel	7.1

d - estimated with using standard SDUCR cutter heads from MAQ.

Standard: PSC63 (with SL interface and exchangeable heads)

Standard: PSC63 (with SL interface and exchangeable heads)									
Part number	Type	Backend	D (mm)	Dmin (mm) ^d	LF (mm)	LB1 (mm)	Screws	Material	
300506	STMD PSC63 16-064 SL16 3C	PSC63	16	20	102	64	M3X8	Steel	1.0
300507	STMD PSC63 16-096 SL16 3C	PSC63	16	20	134	96	M3X8	Steel	1.2
300508	STMD PSC63 20-090 SL20 3C	PSC63	20	20	128	90	M3X8	Steel	1.0
300509	STMD PSC63 20-130 SL20 3C	PSC63	20	25	168	130	M3X8	Steel	1.2
300510	STMD PSC63 25-130 SL25 3C	PSC63	25	32	168	130	M4X9	Steel	1.5
300511	STMD PSC63 25-180 SL25 3C	PSC63	25	32	218	180	M4X9	Steel	1.6
300512	STMD PSC63 25-230 SL25 3C	PSC63	25	32	268	230	M4X9	Steel	1.7
300513	STMD PSC63 32-170 SL32 3C	PSC63	32	40	208	170	M5X12	Steel	1.8
300514	STMD PSC63 32-230 SL32 3C	PSC63	32	40	268	230	M5X12	Steel	2.2
300515	STMD PSC63 32-294 SL32 3C	PSC63	32	40	332	294	M5X12	Steel	2.7
300516	STMD PSC63 40-210 SL40 3C	PSC63	40	50	248	210	M6X14	Steel	2.6
300517	STMD PSC63 40-290 SL40 3C	PSC63	40	50	328	290	M6X14	Steel	3.9
300518	STMD PSC63 40-370 SL40 3C ^a	PSC63	40	50	408	370	M6x14	Steel	4.2
301186	STMD PSC63 50-270 SL40 L 1C	PSC63	50	60	308	270	M6x14	Steel	5.7
301187	STMD PSC63 50-370 SL40 L 1C	PSC63	50	60	408	370	M6x14	Steel	7.6
301188	STMD PSC63 50-470 SL40 L 1C	PSC63	50	60	508	470	M6x14	Steel	9.3
301192	STMD PSC63 60-330 SL40 L 1C	PSC63	60	70	368	330	M6x14	Steel	8.0
301193	STMD PSC63 60-450 SL40 L 1C	PSC63	60	70	488	450	M6x14	Steel	10.6
301202	STMD PSC63 50-270 SL40 R 1C	PSC63	50	60	308	270	M6x14	Steel	5.7
301203	STMD PSC63 50-370 SL40 R 1C	PSC63	50	60	408	370	M6x14	Steel	7.6
301204	STMD PSC63 50-470 SL40 R 1C	PSC63	50	60	508	470	M6x14	Steel	9.3
301205	STMD PSC63 60-330 SL40 R 1C	PSC63	60	70	368	330	M6x14	Steel	8.0
301206	STMD PSC63 60-450 SL40 R 1C	PSC63	60	70	488	450	M6x14	Steel	10.6

d - estimated with using standard SDUCR cutter heads from MAQ.

Standard: PSC80 (with SL interface and exchangeable heads)

Standard: PSC80 (with SL interface and exchangeable heads)									
Part number	Type	Backend	D (mm)	Dmin (mm) ^d	LF (mm)	LB1 (mm)	Screws	Material	
300519	STMD PSC80 16-064 SL16 3C	PSC80	16	20	94	64	M3X8	Steel	1.1
300520	STMD PSC80 16-096 SL16 3C	PSC80	16	20	126	96	M3X8	Steel	1.3
300521	STMD PSC80 20-090 SL20 3C	PSC80	20	25	120	90	M3X8	Steel	1.4
300522	STMD PSC80 20-130 SL20 3C	PSC80	20	25	160	130	M3X8	Steel	1.6
300523	STMD PSC80 25-130 SL25 3C	PSC80	25	32	160	130	M4X9	Steel	2.0
300524	STMD PSC80 25-180 SL25 3C	PSC80	25	32	210	180	M4X9	Steel	2.5
300525	STMD PSC80 25-230 SL25 3C	PSC80	25	32	260	230	M4X9	Steel	3.0
300526	STMD PSC80 32-170 SL32 3C	PSC80	32	40	200	170	M5X12	Steel	2.8
300527	STMD PSC80 32-230 SL32 3C	PSC80	32	40	260	230	M5X12	Steel	3.6
300528	STMD PSC80 32-294 SL32 3C	PSC80	32	40	324	294	M5X12	Steel	4.5
300529	STMD PSC80 40-210 SL40 3C	PSC80	40	50	240	210	M6X14	Steel	3.7
300530	STMD PSC80 40-290 SL40 3C	PSC80	40	50	320	290	M6x14	Steel	5.2
300531	STMD PSC80 40-370 SL40 3C ^a	PSC80	40	50	400	370	M6x14	Steel	5.4
301189	STMD PSC80 50-270 SL40 L 1C	PSC80	50	60	302	270	M6x14	Steel	6.4
301190	STMD PSC80 50-370 SL40 L 1C	PSC80	50	60	402	370	M6x14	Steel	8.3
301191	STMD PSC80 50-470 SL40 L 1C	PSC80	50	60	502	470	M6x14	Steel	10.0
301194	STMD PSC80 60-330 SL40 L 1C	PSC80	60	70	362	330	M6x14	Steel	8.7
301195	STMD PSC80 60-450 SL40 L 1C	PSC80	60	70	482	450	M6x14	Steel	11.3
301196	STMD PSC80 60-570 SL40 L 1C	PSC80	60	70	602	570	M6x14	Steel	13.2
301207	STMD PSC80 50-270 SL40 R 1C	PSC80	50	60	302	270	M6x14	Steel	6.4
301208	STMD PSC80 50-370 SL40 R 1C	PSC80	50	60	402	370	M6x14	Steel	8.3
301209	STMD PSC80 50-470 SL40 R 1C	PSC80	50	60	502	470	M6x14	Steel	10.0
301210	STMD PSC80 60-330 SL40 R 1C	PSC80	60	70	362	330	M6x14	Steel	8.7
301211	STMD PSC80 60-450 SL40 R 1C	PSC80	60	70	482	450	M6x14	Steel	11.3
301212	STMD PSC80 60-570 SL40 R 1C	PSC80	60	70	602	570	M6x14	Steel	13.2
301197	STMD PSC80 80-450 SL40 L 1C	PSC80	80	90	482	450	M6x14	Steel	12.1
301198	STMD PSC80 80-610 SL40 L 1C	PSC80	80	90	642	610	M6x14	Steel	18.2
301199	STMD PSC80 80-740 SL40 L 1C	PSC80	80	90	742	740	M6x14	Steel	20.6

d - estimated with using standard SDUCR cutter heads from MAQ.
--

Standard: HSK63T (with SL interface and exchangeable heads)

Standard: HSK63T (with SL interface and exchangeable heads)									
Part number	Type	Backend	D (mm)	Dmin (mm) ^d	LF (mm)	LB1 (mm)	Screws	Material	
300532	STMD HSK63T 16-064 SL16 3C	HSK63	16	20	120	64	M3X8	Steel	1.0
300533	STMD HSK63T 16-096 SL16 3C	HSK63	16	20	152	96	M3X8	Steel	1.2
300534	STMD HSK63T 20-090 SL20 3C	HSK63	20	25	146	90	M3X8	Steel	1.0
300535	STMD HSK63T 20-130 SL20 3C	HSK63	20	25	186	130	M3X8	Steel	1.2
300536	STMD HSK63T 25-130 SL25 3C	HSK63	25	32	186	130	M4X9	Steel	1.5
300537	STMD HSK63T 25-180 SL25 3C	HSK63	25	32	236	180	M4X9	Steel	1.6
300538	STMD HSK63T 25-230 SL25 3C	HSK63	25	32	286	230	M4X9	Steel	1.7
300539	STMD HSK63T 32-170 SL32 3C	HSK63	32	40	226	170	M5X12	Steel	1.8
300540	STMD HSK63T 32-230 SL32 3C	HSK63	32	40	286	230	M5X12	Steel	2.2
300541	STMD HSK63T 32-294 SL32 3C	HSK63	32	40	350	294	M5X12	Steel	2.7
300542	STMD HSK63T 40-210 SL40 3C	HSK63	40	50	266	210	M6X14	Steel	2.6
300543	STMD HSK63T 40-290 SL40 3C	HSK63	40	50	346	290	M6x14	Steel	3.9
300544	STMD HSK63T 40-370 SL40 3C ^a	HSK63	40	50	426	370	M6x14	Steel	4.2

d - estimated with using standard SDUCR cutter heads from MAQ.

Tools with KL interface

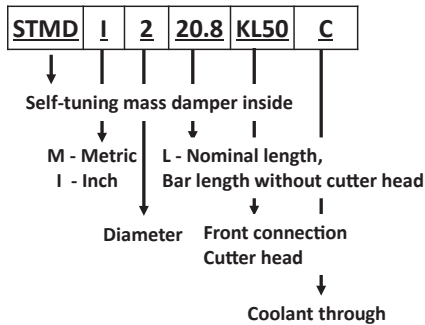
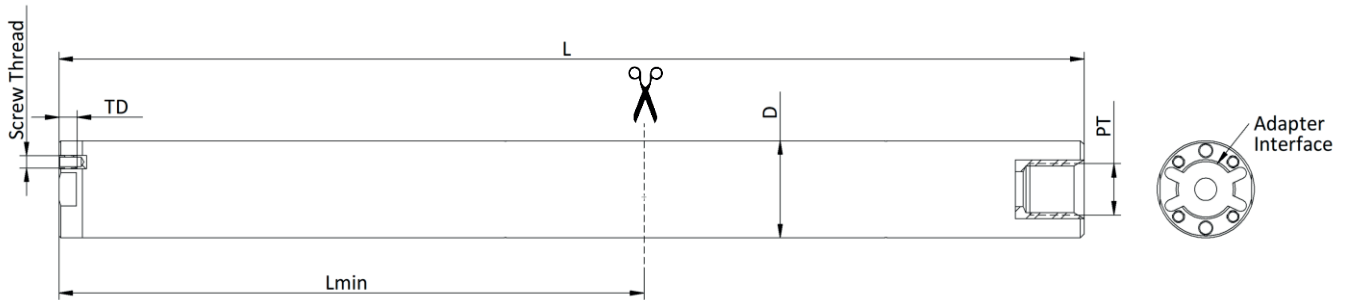

L – nominal length
L_{min} – minimum total length after cutting
L_c – recommended clamping length, 3 times diameter
D – diameter
PT – pipe thread
TD – thread depth

C – Coolant through

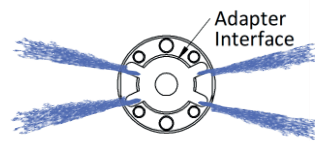

Standard: Metric (with KL interface and exchangeable heads)										
Part number	Type	Workable length ^c (mm)	D min (mm) ^g	Lmin (mm)	Lc (mm)	Screws	TD (mm)	PT	Material	KG
300648	STMD M50-528-KL50 C ^{a,b}	300-400	60	322	150	1/4"-20 x 1/2	9	G 3/4	Steel	8.0
300649	STMD M60-642-KL60 C ^{a,b}	360-480	70	422	180	5/16"-18 x 1/2	12	G 3/4	Steel	13.6

Standard: Inch (with KL interface and exchangeable heads)										
Part number	Type	Workable length ^c (inch)	D min (inch) ^g	Lmin (inch)	Lc (inch)	Screws	TD (mm)	PT	Material	KG
300650	STMD I 2-20.8-KL50 C ^{a,b}	12.000-16.000	2.362	12.7	5.90	1/4"-20 x 1/2	9	G 3/4	Steel	8.0
300651	STMD I 2 1/2-25.3-KL60 C ^{a,b}	15.000-20.000	2.756	16.7	7.10	5/16"-18 x 1/2	12	G 3/4	Steel	13.6

Standard: Metric (with KL interface and exchangeable heads)										
Part number	Type	Workable length ^c (mm)	D min (mm) ^g	Lmin (mm)	Lc (mm)	Screws	TD (mm)	PT	Material	KG
300646	STMD M50-670-KL50 C ^{a,b}	400-550	60	384	150	1/4"-20 x 1/2	9	G 3/4	Steel	9.4
300647	STMD M60-822-KL60 C ^{a,b}	480-660	70	484	180	5/16"-18 x 1/2	12	G 3/4	Steel	16.4

Standard: Inch (with KL interface and exchangeable heads)										
Part number	Type	Workable length ^c (inch)	D min (inch) ^g	Lmin (inch)	Lc (inch)	Screws	TD (mm)	PT	Material	KG
300637	STMD I 2-26.4-KL50 C ^{a,b}	16.000-22.000	2.362	15.0	5.90	1/4"-20 x 1/2	9	G 3/4	Steel	9.4
300638	STMD I 2 1/2-32.4-KL60 C ^{a,b}	20.000-27.500	2.756	19.1	7.10	5/16"-18 x 1/2	12	G 3/4	Steel	16.4

a – delivery time 3 weeks
b – exchangeable to KM Lock i interface
c – measured from the cutting edge to the clamping.
g – estimated with standard KM Lock SDUCR cutter head

Burnishing

Diamond burnishing Right hand

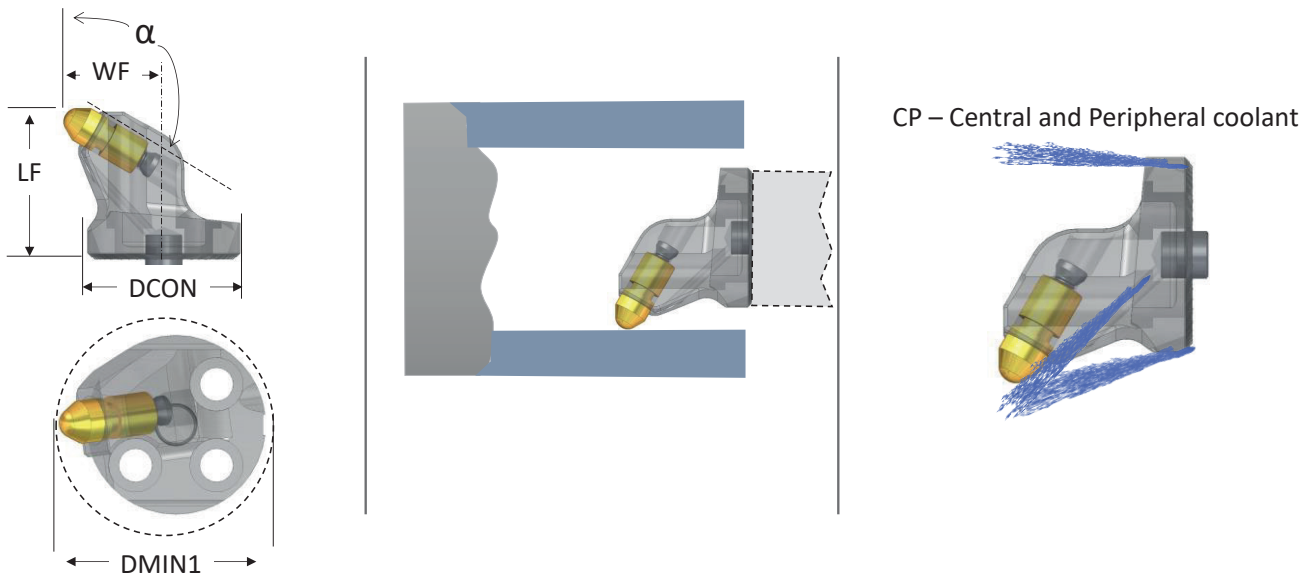

Part Number	Type	DCON (mm)	DMIN1 (mm)	LF (mm)	WF (mm)	α (°)	Burnishing Nib	Nib screw	KG
300631	SL20 DB CP	SL 20	24	21	12	30	R 061402	IS M3x7	0.02
300632	SL25 DB CP	SL 25	30	25	16	30	R 061402	IS M3x7	0.04
300633	SL32 DB CP	SL 32	38	33	20	30	R 061402	IS M3x7	0.07
300634	SL40 DB CP	SL 40	43	34	24	30	R 061402	IS M3x7	0.14

All burnishing heads are delivered with the burnishing nib and nib screw.

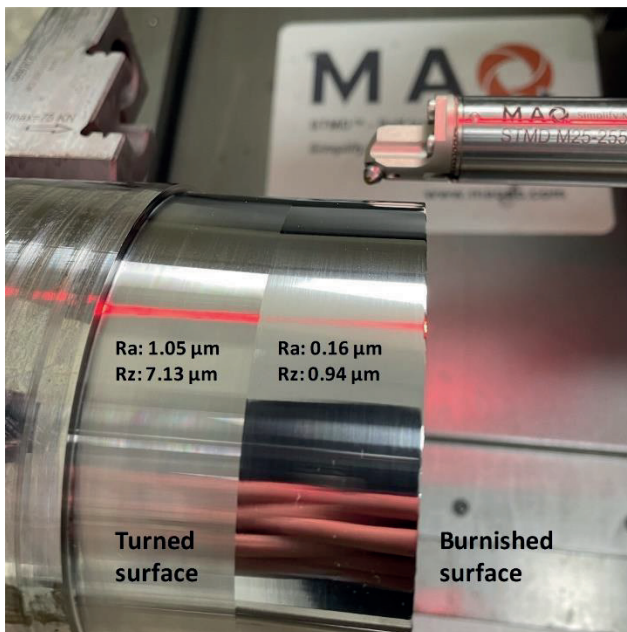

Mirror surface finish in one pass, up to 15xD!

The MAQ diamond burnishing tool works on carbon steel, tool steel, cast iron, ferrous and non-ferrous (P, M, K, N, S) materials.

Suggested starting machining parameter to all materials:

- Interference with workpiece material 0.05-0.2 mm (0.002-0.003 inch)
- Cutting speed 60-230 m/min (200-750 SFM)
- Feed rate 0.08-0.15 mm/rev (0.003-0.006 IPR)

We recommend a feed rate at 70% of the feed rate in previous turning operation.

We recommend start with interference of 0.1 mm (0.004 µinch) and increase the interference if the surface finish is not reached.

Recommended surface finish prior burnishing operation is Ra < 1.6 µm (64 µinch). After burnishing, the surface finish can normally reach Ra < 0.3 µm.

Diamond burnishing works well on STMD tools and can reach mirror surface finish up to **15xD** setup.

Note: diamond burnishing normally has negligible impact on the size of the bore. A typical bore size change in burnishing of high alloy steel 4340 is within 10-15 µm (0.0004-0.0006 inch).

End-effecters

SDUCR, SDUCL for DCMT Inserts

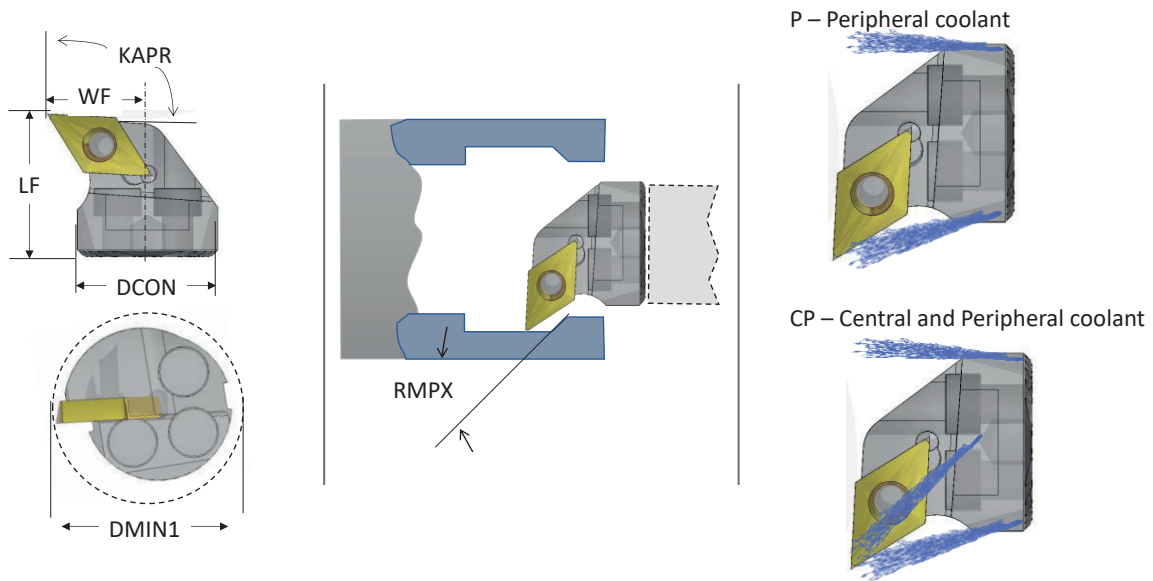

Part Number	Type	DMIN1 (mm)	LF (mm)	WF (mm)	KAPR (°)	RMPX (°)	Master insert	Insert screw	KG
300118	SL12 SDUCL P ^a	16	14	9	93	30	DCMT 070204	IS M2.5x6.0	0.01
300059	SL12 SDUCR P ^a	16	14	9	93	30	DCMT 070204	IS M2.5x6.0	0.01
300119	SL16 SDUCL P ^a	20	16	11	93	30	DCMT 070204	IS M2.5x6.0	0.01
300060	SL16 SDUCR P ^a	20	16	11	93	30	DCMT 070204	IS M2.5x6.0	0.01
300120	SL20 SDUCL P ^a	25	20	13	93	30	DCMT 11T304	IS M3.5x10.0	0.02
300061	SL20 SDUCR P ^a	25	20	13	93	30	DCMT 11T304	IS M3.5x10.0	0.02
300121	SL25 SDUCL P ^a	32	22	17	93	30	DCMT 11T304	IS M3.5x10.0	0.04
300062	SL25 SDUCR P ^a	32	22	17	93	30	DCMT 11T304	IS M3.5x10.0	0.04
300122	SL32 SDUCL P ^a	40	27	22	93	30	DCMT 11T304	IS M3.5x10.0	0.07
300063	SL32 SDUCR P ^a	40	27	22	93	30	DCMT 11T304	IS M3.5x10.0	0.07
300064	SL40 SDUCR P ^a	50	32	27	93	30	DCMT 11T304	IS M3.5x10.0	0.14
300209	SL40 SDUCL CP ^b	50	32	27	93	30	DCMT 11T304	IS M3.5x10.0	0.14
300195	SL40 SDUCR CP ^b	50	32	27	93	30	DCMT 11T304	IS M3.5x10.0	0.14

All cutter heads are delivered with the insert clamp screw and torx key

a - P - Peripheral coolant works for SL connection with 3C

b - CP - Central and Peripheral coolant works with SL connection with both 1C and 3C

SDQCR for DCMT Inserts

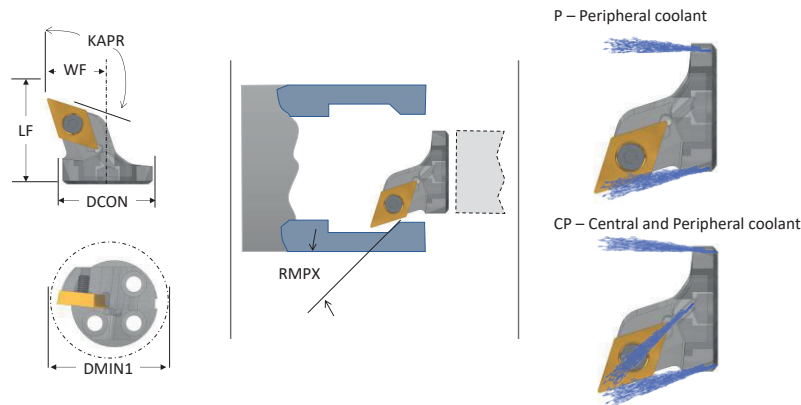

Part Number	Type	DMIN1 (mm)	LF (mm)	WF (mm)	KAPR (°)	RMPX (°)	Master insert	Insert screw	KG
300545	SL16 SDQCR P ^a	20	18	11	107.5	17	DCMT 070204	IS M2.5x6.0	0.01
300546	SL20 SDQCR CP ^b	25	24	13	107.5	17	DCMT 11T304	IS M3.5x10.0	0.02
300547	SL25 SDQCR CP ^b	32	24	17	107.5	17	DCMT 11T304	IS M3.5x10.0	0.04
300548	SL32 SDQCR CP ^b	40	26	22	107.5	17	DCMT 11T304	IS M3.5x10.0	0.07
300549	SL40 SDQCR CP ^b	50	26	27	107.5	17	DCMT 11T304	IS M3.5x10.0	0.14

All cutter heads are delivered with the insert clamp screw and torx key
a - P - Peripheral coolant works for SL connection with 3C
b - CP -Central and Peripheral coolant works with SL connection with both 1C and 3C

SDXCR for DCMT Inserts

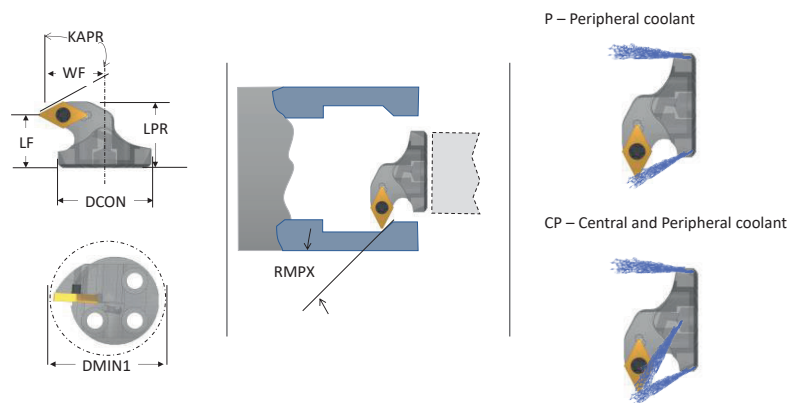

Part Number	Type	DMIN1 (mm)	LF (mm)	LPR (mm)	WF (mm)	KAPR (°)	RMPX (°)	Master insert	Insert screw	KG
300550	SL16 SDXCR CP ^a	22	12.5	16	13	62.5	60	DCMT 070204	IS M2.5x6.0	0.01
300551	SL20 SDXCR CP ^b	27	13	17	15	62.5	60	DCMT 070204	IS M2.5x8.0	0.02
300552	SL25 SDXCR CP ^b	33	14	17.6	18	62.5	60	DCMT 070204	IS M2.5x8.0	0.04
300553	SL32 SDXCR CP ^b	40	17	22.5	22	62.5	60	DCMT 11T304	IS M3.5x10.0	0.07
300554	SL40 SDXCR CP ^b	50	17	22	27	62.5	60	DCMT 11T304	IS M3.5x10.0	0.14

All cutter heads are delivered with the insert clamp screw and torx key
a - P - Peripheral coolant works for SL connection with 3C
b - CP -Central and Peripheral coolant works with SL connection with both 1C and 3C

Back boring – B-SDUCR for DCMT Inserts

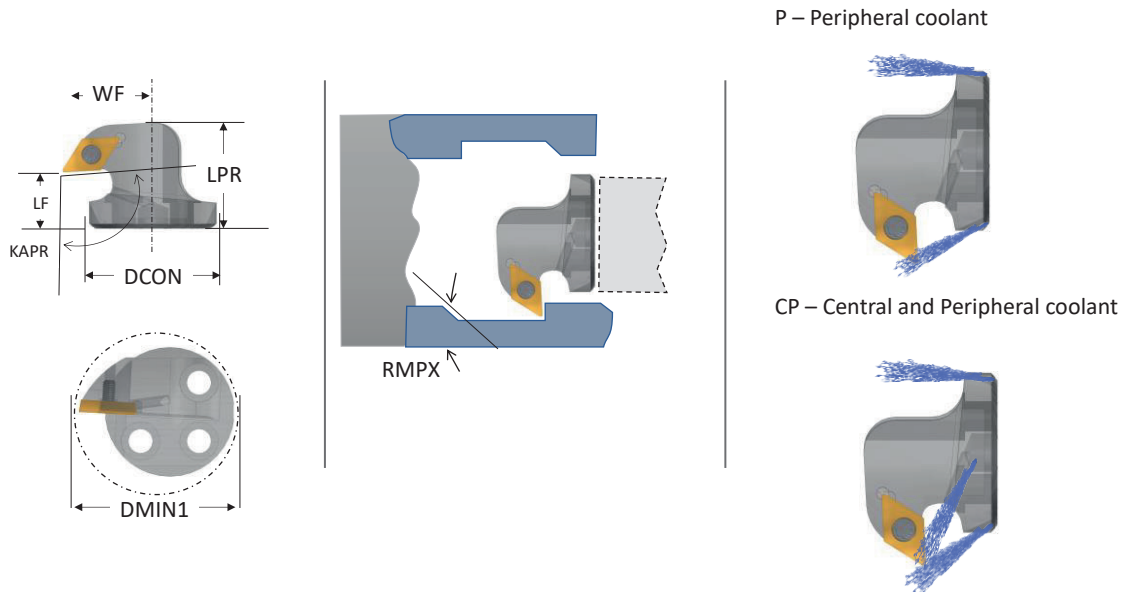

Part Number	Type	DMIN1 (mm)	LF (mm)	LPR (mm)	WF (mm)	KAPR (°)	RMPX (°)	Master insert	Insert screw	KG
300555	SL16 B-SDUCR CP ^a	20	11	20	13	93	30	DCMT 070204	IS M2.5x6.0	0.01
300556	SL20 B-SDUCR CP ^a	25	11	20	15	93	30	DCMT 070204	IS M2.5x6.0	0.02
300557	SL25 B-SDUCR CP ^a	32	11	21	18	93	30	DCMT 070204	IS M2.5x8.0	0.04
300558	SL32 B-SDUCR CP ^a	40	13	27	22	93	30	DCMT 11T304	IS M3.5x10.0	0.07
300559	SL40 B-SDUCR CP ^a	50	15	29	27	93	30	DCMT 11T304	IS M3.5x10.0	0.14

All cutter heads are delivered with the insert clamp screw and torx key
a - CP -Central and Peripheral coolant exits

STFCR, STFCL for TCMT Inserts

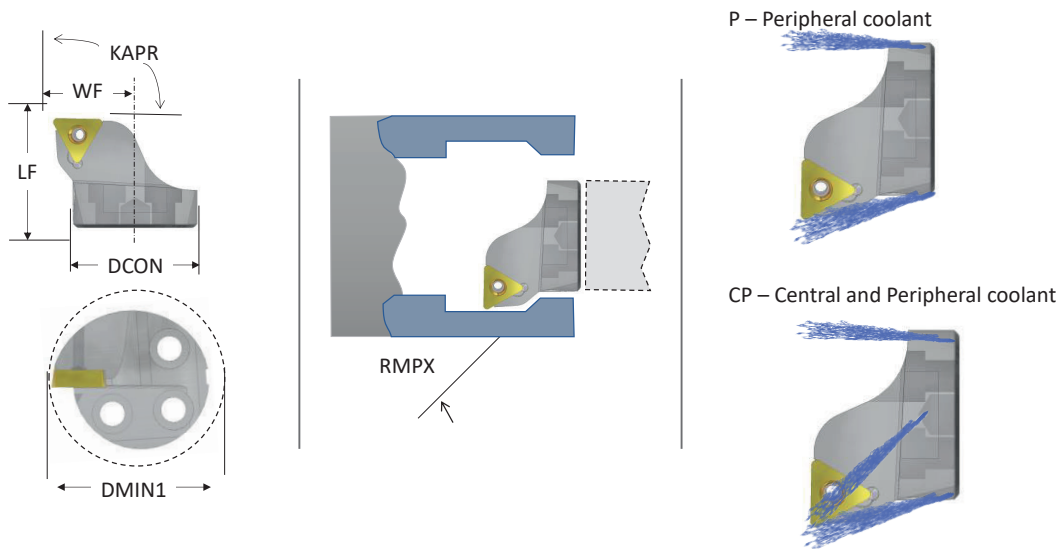

Part Number	Type	DMIN1 (mm)	LF (mm)	WF (mm)	KAPR (°)	RMPX (°)	Master insert	Insert screw	KG
300124	SL12 STFCL P ^a	16	14	9	91	NA	TCMT 090204	IS M2.2x5.0	0.01
300065	SL12 STFCR P ^a	16	14	9	91	NA	TCMT 090204	IS M2.2x5.0	0.01
300125	SL16 STFCL P ^a	20	16	11	91	NA	TCMT 090204	IS M2.2x5.0	0.01
300066	SL16 STFCR P ^a	20	16	11	91	NA	TCMT 090204	IS M2.2x5.0	0.01
300126	SL20 STFCL P ^a	25	20	13	91	NA	TCMT 110304	IS M2.5x8.0	0.02
300067	SL20 STFCR P ^a	25	20	13	91	NA	TCMT 110304	IS M2.5x8.0	0.02
300127	SL25 STFCL P ^a	32	22	17	91	NA	TCMT 110304	IS M2.5x8.0	0.04
300068	SL25 STFCR P ^a	32	22	17	91	NA	TCMT 110304	IS M2.5x8.0	0.04
300128	SL32 STFCL P ^a	40	27	22	91	NA	TCMT 16T304	IS M3.5x10.0	0.07
300069	SL32 STFCR P ^a	40	27	22	91	NA	TCMT 16T304	IS M3.5x10.0	0.07
300070	SL40 STFCR P ^a	50	32	27	91	NA	TCMT 16T304	IS M3.5x10.0	0.14
300210	SL40 STFCL CP ^b	50	32	27	91	NA	TCMT 16T304	IS M3.5x10.0	0.14
300197	SL40 STFCR CP ^b	50	32	27	91	NA	TCMT 16T304	IS M3.5x10.0	0.14

All cutter heads are delivered with the insert clamp screw and torx key

a - P - Peripheral coolant works for SL connection with 3C

b - CP - Central and Peripheral coolant works with SL connection with both 1C and 3C

STFPR for TPMT Inserts

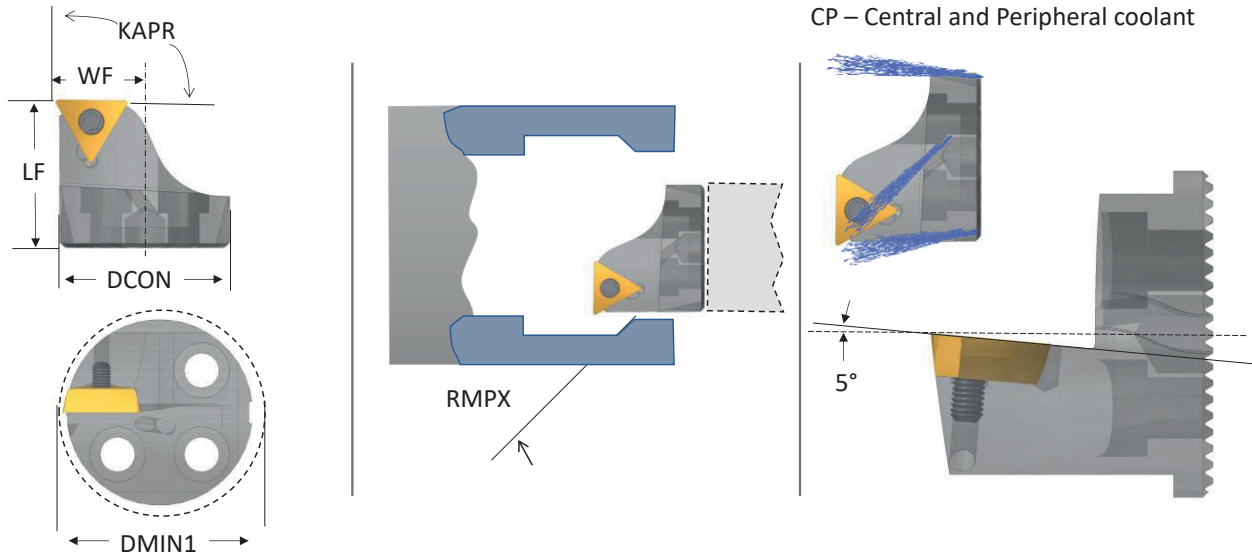

Part Number	Type	DMIN1 (mm)	LF (mm)	WF (mm)	KAPR (°)	RMPX (°)	Master insert	Insert screw	KG
300466	SL16 STFPR CP ^a	18	17	8.8	91	NA	TPMT 090204	IS M2.2x5.0	0.01
300467	SL20 STFPR CP ^a	22	19	10.8	91	NA	TPMT 110304	IS M2.5x8.0	0.02
300468	SL25 STFPR CP ^a	27	22	13.3	91	NA	TPMT 110304	IS M2.5x8.0	0.04

All cutter heads are delivered with the insert clamp screw and torx key

a - CP -Central and Peripheral coolant works with SL connection with both 1C and 3C

SCLCR, SCLCL for CCMT Inserts

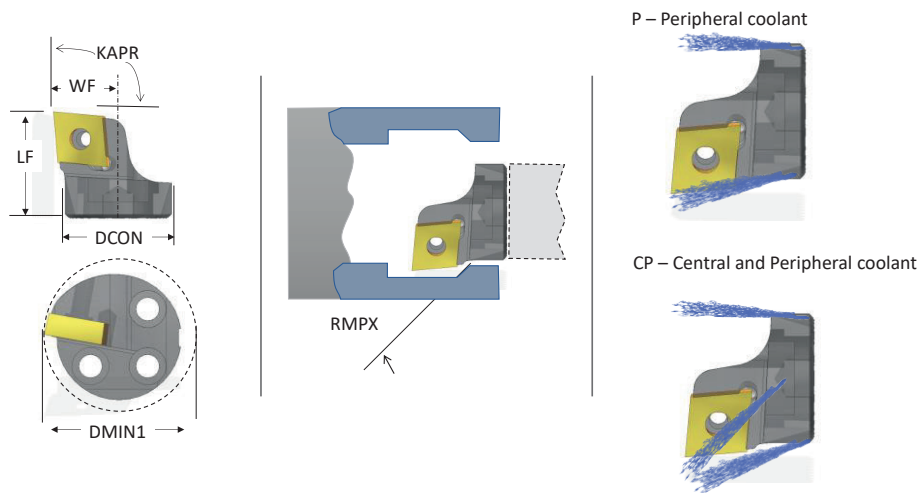

Part Number	Type	DMIN1 (mm)	LF (mm)	WF (mm)	KAPR (°)	RMPX (°)	Master Insert	Insert screw	KG
300112	SL12 SCLCL P ^a	16	14.4	10	95	NA	CCMT 060204	IS M2.5x6.0	0.01
300071	SL12 SCLCR P ^a	16	14.4	10	95	NA	CCMT 060204	IS M2.5x6.0	0.01
300113	SL16 SCLCL P ^a	20	15.4	11	95	NA	CCMT 060204	IS M2.5x6.0	0.01
300072	SL16 SCLCR P ^a	20	15.4	11	95	NA	CCMT 060204	IS M2.5x6.0	0.01
300114	SL20 SCLCL P ^a	25	19.1	13	95	NA	CCMT 09T304	IS M3.5x10.0	0.02
300073	SL20 SCLCR P ^a	25	19.1	13	95	NA	CCMT 09T304	IS M3.5x10.0	0.02
300115	SL25 SCLCL P ^a	32	21.1	17	95	NA	CCMT 09T304	IS M3.5x10.0	0.04
300074	SL25 SCLCR CP ^a	32	21.1	17	95	NA	CCMT 09T304	IS M3.5x10.0	0.04
300116	SL32 SCLCL P ^a	40	24.1	22	95	NA	CCMT 09T304	IS M3.5x10.0	0.07
300075	SL32 SCLCR P ^a	40	24.1	22	95	NA	CCMT 09T304	IS M3.5x10.0	0.07
300076	SL40 SCLCR P ^a	50	25.1	27	95	NA	CCMT 09T304	IS M3.5x10.0	0.14
300208	SL40 SCLCL CP ^b	50	25.1	27	95	NA	CCMT 120404	IS M4.0x15.0	0.14
300196	SL40 SCLCR CP ^b	50	25.1	27	95	NA	CCMT 120404	IS M4.0x15.0	0.14

All cutter heads are delivered with the insert clamp screw and torx key

a - P - Peripheral coolant works for SL connection with 3C

b - CP - Central and Peripheral coolant works with SL connection with both 1C and 3C

SVUCR, SVUCL for VCMT Inserts

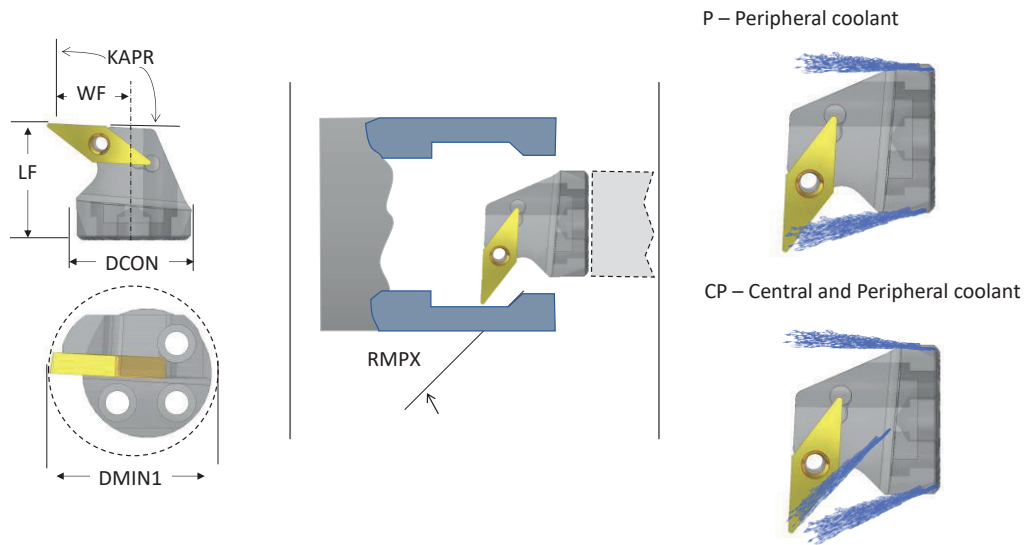

Part Number	Type	DMIN (mm)	LF (mm)	WF (mm)	KAPR (°)	RMPX (°)	Master Insert	Insert screw	KG
300666	SL16 SVUCR P ^{a,c}	25	17	16	93	45	VCMT 110304	IS M2.5x6.0	0.02
300199	SL20 SVUCL P ^a	27	20.5	15	93	45	VCMT 110304	IS M2.5x8.0	0.02
300198	SL20 SVUCR P ^a	27	20.5	15	93	45	VCMT 110304	IS M2.5x8.0	0.02
300201	SL25 SVUCL P ^a	33	20.5	18	93	45	VCMT 110304	IS M2.5x8.0	0.04
300200	SL25 SVUCR P ^a	33	20.5	18	93	45	VCMT 110304	IS M2.5x8.0	0.04
300598	SL32 SVUCL CP ^{b,c}	40	25	22	93	45	VCMT 160404	IS M3.5x10.0	0.08
300597	SL32 SVUCR CP ^b	40	25	22	93	45	VCMT 160404	IS M3.5x10.0	0.08
300560	SL40 SVUCL CP ^b	50	28	27	93	45	VCMT 160404	IS M3.5x10.0	0.12
300561	SL40 SVUCR CP ^b	50	28	27	93	45	VCMT 160404	IS M3.5x10.0	0.12

All cutter heads are delivered with the insert clamp screw and torx key

a - P - Peripheral coolant works for SL connection with 3C

b - CP - Central and Peripheral coolant works with SL connection with both 1C and 3C

c - available after Sep. 2023

Back boring – B-SVUCR for VCMT Inserts

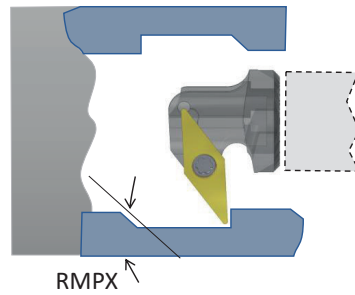
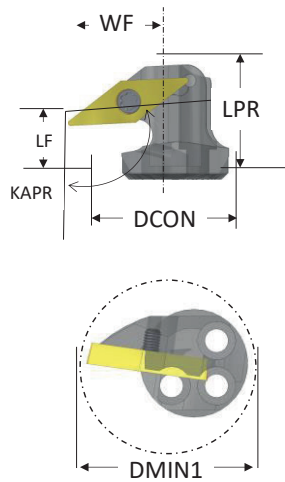

P – Peripheral coolant

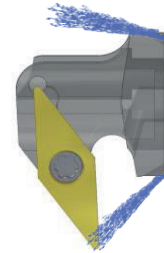

CP – Central and Peripheral coolant

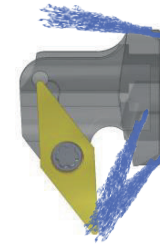

Part Number	Type	DMIN1 (mm)	LF (mm)	LPR (mm)	WF (mm)	KAPR (°)	RMPX (°)	Master insert	Insert screw	KG
300667	SL16 B SVUCR CP ^b	25	8	17	16	93	45	VCMT 110304	IS M2.5x6.0	0.02

All cutter heads are delivered with the insert clamp screw and torx key

a - P - Peripheral coolant works for SL connection with 3C

b - CP - Central and Peripheral coolant works with SL connection with both 1C and 3C

PDUNR, PDUNL for DNMG Inserts

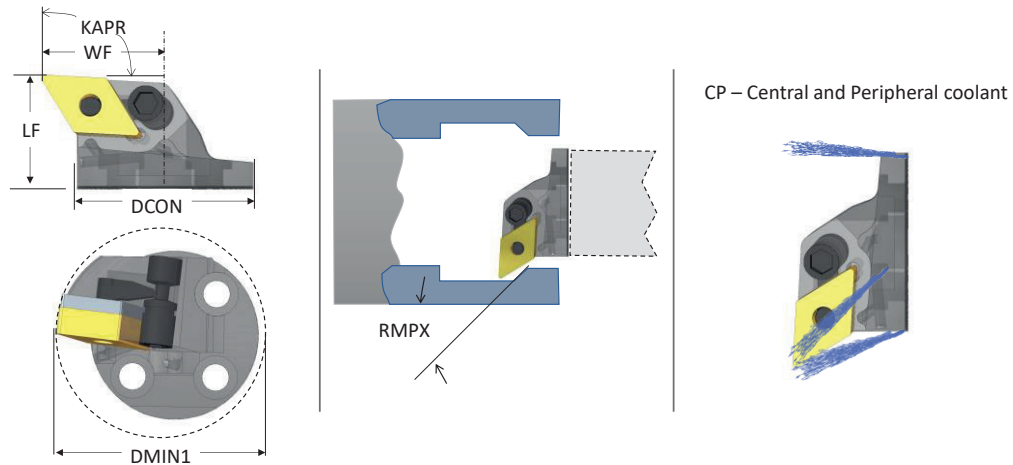

Part Number	Type	DMIN1 (mm)	LF (mm)	WF (mm)	KAPR (°)	RMPX (°)	Insert	Slot screw	Level	Shim	
300661	SL25 PDUNL CP ^a	34	23	19	93	27	DNMG 1104XX	M5x0.8x15	LV3 G0310	PS DNMG 1104	0.05
300660	SL25 PDUNR CP ^a	34	23	19	93	27	DNMG 1104XX	M5x0.8x15	LV3 G0310	PS DNMG 1104	0.05
300562	SL32 PDUNL CP ^a	40	26	22	93	27	DNMG 1104XX	M6x1x17	LV3 G0312	PS DNMG 1104	0.09
300427	SL32 PDUNR CP ^a	40	26	22	93	27	DNMG 1104XX	M6x1x17	LV3 G0312	PS DNMG 1104	0.09
300402	SL40 PDUNL CP ^a	50	26	30	93	27	DNMG 1506XX	M8x1x21	LV4 G0516	PS DNMG 1506	0.14
300086	SL40 PDUNR CP ^a	50	26	30	93	27	DNMG 1506XX	M8x1x21	LV4 G0516	PS DNMG 1506	0.14

All cutter heads are delivered with the insert clamp screw and torx key
a - CP -Central and Peripheral coolant works with SL connection with both 1C and 3C

PTFNR, PTFNL for TNMG Inserts

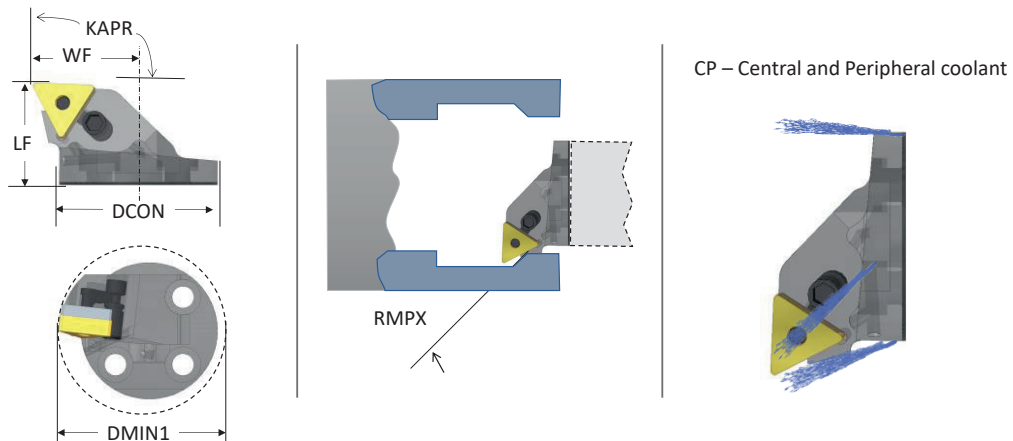

Part Number	Type	DMIN1 (mm)	LF (mm)	WF (mm)	KAPR (°)	RMPX (°)	Insert	Slot screw	Level	Shim	
300429	SL32 PTFNR CP ^a	40	27	22	91	NA	TNMG 1604XX	M6x1x17	LV3 G0310	PS TNMG 1604	0.09
300563	SL32 PTFNL CP ^a	40	27	22	91	NA	TNMG 1604XX	M6x1x17	LV3 G0310	PS TNMG 1604	0.09
300088	SL40 PTFNR CP ^a	50	26	27	91	NA	TNMG 1604XX	M6x1x17	LV3 G0310	PS TNMG 1604	0.14
300403	SL40 PTFNL CP ^a	50	26	27	91	NA	TNMG 1604XX	M6x1x17	LV3 G0310	PS TNMG 1604	0.14

All cutter heads are delivered with the insert clamp screw and torx key
a - CP -Central and Peripheral coolant works with SL connection with both 1C and 3C

PCLNR, PCLNL for CNMG Inserts

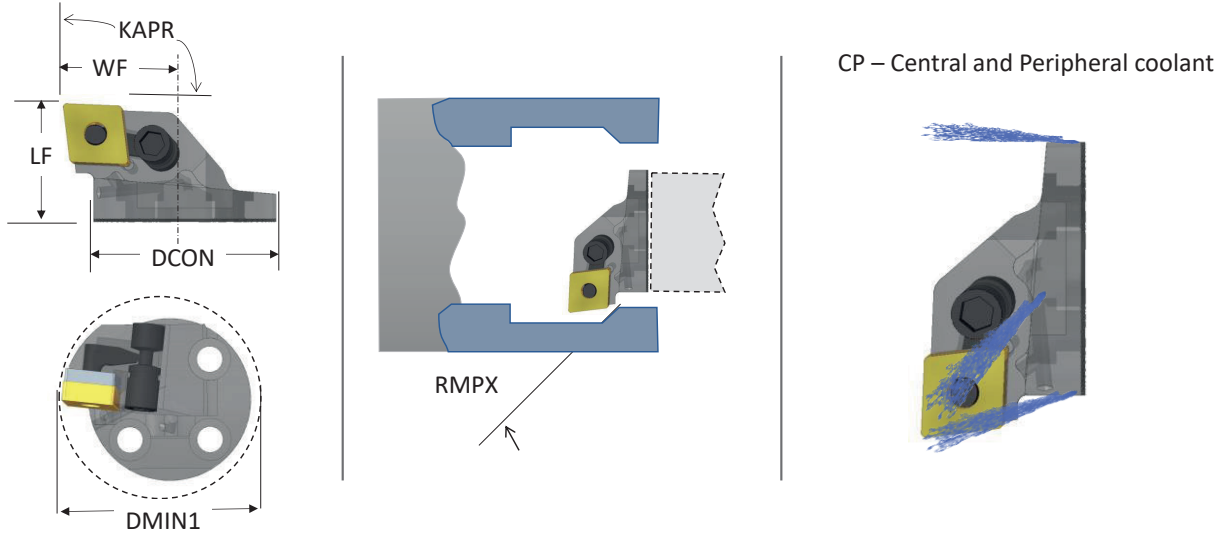

Part Number	Type	DMIN1 (mm)	LF (mm)	WF (mm)	KAPR (°)	RMPX (°)	Insert	Slot screw	Level	Shim	KG
300428	SL32 PCLNR CP ^a	40	26	22	95	NA	CNMG 1204XX	M6x1x17	LV4 G0513	PS CNMG 1204	0.09
300564	SL32 PCLNL CP ^a	40	26	22	95	NA	CNMG 1204XX	M6x1x17	LV4 G0513	PS CNMG 1204	0.09
300087	SL40PCLNR CP ^a	50	26	27	95	NA	CNMG 1204XX	M8x1x21	LV4 G0513	PS CNMG 1204	0.14
300404	SL40 PCLNL CP ^a	50	26	27	95	NA	CNMG 1204XX	M8x1x21	LV4 G0513	PS CNMG 1204	0.14

All cutter heads are delivered with the insert clamp screw and torx key
a - CP -Central and Peripheral coolant works with SL connection with both 1C and 3C

PWLNR, PWLNL for WNMG Inserts

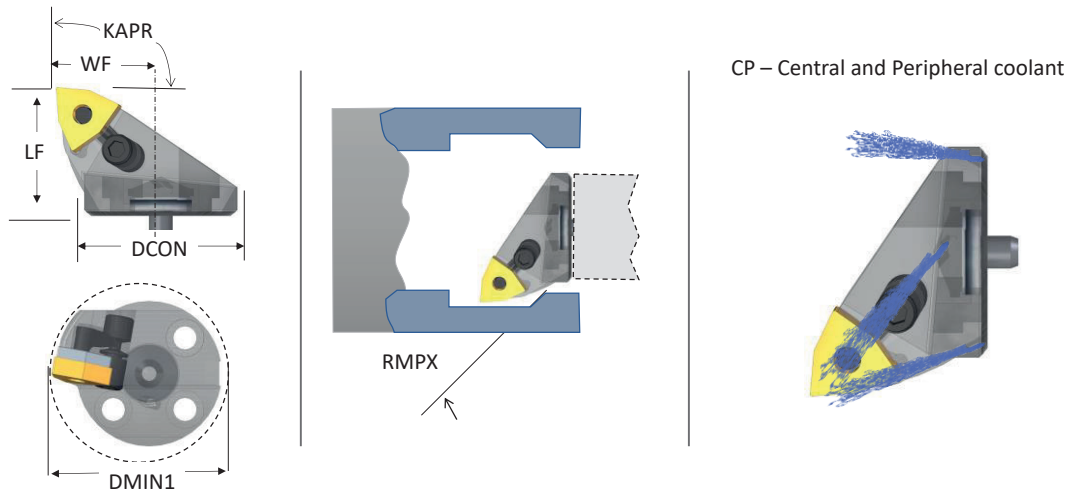

Part Number	Type	DCON (mm)	DMIN1 (mm)	LF (mm)	WF (mm)	KAP R (°)	RMPX (°)	Insert	Slot screw	Level	Shim	KG
300474	SL40 PWLNR CP ^a	SL 40	50	26	27	95	NA	WNMG 0804XX	M8x1x21	LV4 G0513	PS WNMG 0804	0.14
300475	SL40 PWLNL CP ^a	SL 40	50	26	27	95	NA	WNMG 0804XX	M8x1x21	LV4 G0513	PS WNMG 0804	0.14

All cutter heads are delivered with the insert clamp screw and torx key
a - CP -Central and Peripheral coolant works with SL connection with both 1C and 3C

End effectors - Threading

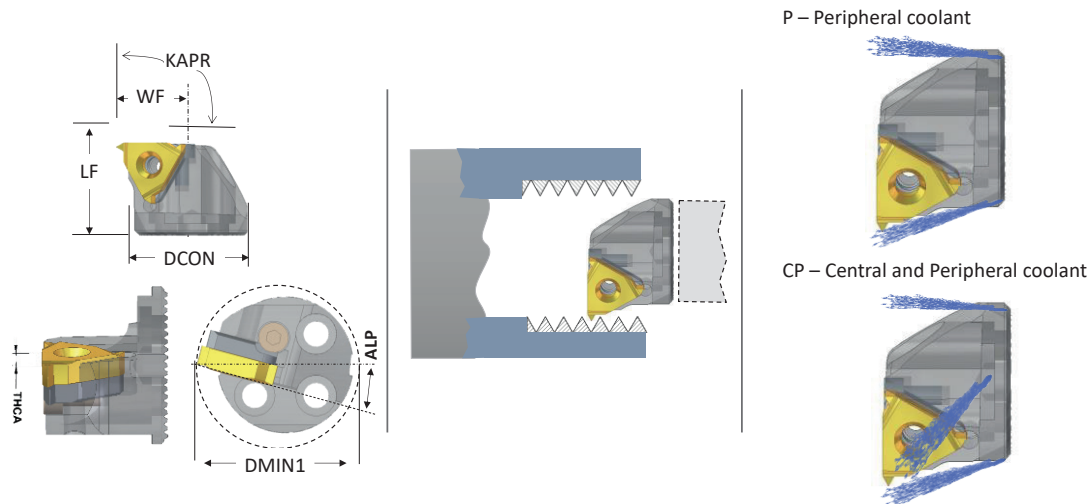

Left hand

Part Number	Type	DMIN1 (mm)	LF (mm)	WF (mm)	Master insert	Insert screw	Shim	Shim screw	ALP	THCA	KG
300268	SL12 SXFNL P ^a 11	16	16	8.9	11 IL A60	IS M2.5x6.0	NA	NA	15 °	2 °	0.01
300269	SL16 SXFNL P ^a 11	20	20	10.4	11 IL A60	IS M2.5x6.0	NA	NA	15 °	1 °	0.01
300270	SL16 SXFNL P ^a 16	20	20	10.4	16 IL AG60	IS M3.5x10.0	NA	NA	15 °	2 °	0.01
300271	SL20 SXFNL P ^a 11	25	20	12.7	11 IL A60	IS M2.5x6.0	NA	NA	15 °	1 °	0.02
300272	SL20 SXFNL P ^a 16	25	23	13.7	16 IL AG60	IS M3.5x11.0	NA	NA	15 °	2 °	0.02
300273	SL25 SXFNL P ^a 16	30	24	16.3	16 IL AG60	IS M3.5x11.0	EA16	HS M3x6	15 °	1 °	0.04
300274	SL25 SXFNL P ^a 22	32	30	18.3	22 IL N60	IS M4.5x12.0	EA22	HS M3x6	15 °	2 °	0.04
300275	SL32 SXFNL P ^a 16	37	28	19.7	16 IL AG60	IS M3.5x10.0	EA16	HS M3x6	15 °	1 °	0.07
300276	SL32 SXFNL CP ^b 22	39	32	21.7	22 IL N60	IS M4.5x12.0	EA22	HS M3x6	15 °	2 °	0.07
300277	SL40 SXFNL CP ^b 16	45	28	23.7	16 IL AG60	IS M3.5x10.0	EA16	HS M3x6	15 °	1 °	0.14
300278	SL40 SXFNL CP ^b 22	47	30	25.7	22 IL N60	IS M4.5x12.0	EA22	HS M3x6	15 °	2 °	0.14
300279	SL40 SXFNL CP ^b 27 ^c	48	35	26.8	27 IL Q60	IS M5.0x18.0	EA27	HS M4x9	15 °	2.5 °	0.14

Right hand

Part Number	Type	DMIN1 (mm)	LF (mm)	WF (mm)	Master insert	Insert screw	Shim	Shim screw	ALP	THCA	KG
300280	SL12 SXFN R P ^a 11	16	16	8.9	11 IR A60	IS M2.5x6.0	NA	NA	15 °	2 °	0.01
300281	SL16 SXFN R P ^a 11	20	20	10.4	11 IR A60	IS M2.5x6.0	NA	NA	15 °	1 °	0.01
300282	SL16 SXFN R P ^a 16	20	20	10.4	16 IR AG60	IS M3.5x10.0	NA	NA	15 °	2 °	0.01
300283	SL20 SXFN R P ^a 11	25	20	12.7	11 IR A60	IS M2.5x6.0	NA	NA	15 °	1 °	0.02
300284	SL20 SXFN R P ^a 16	25	23	13.7	16 IR AG60	IS M3.5x11.0	NA	NA	15 °	2 °	0.02
300285	SL25 SXFN R P ^a 16	30	24	16.3	16 IR AG60	IS M3.5x11.0	IA16	HS M3x6	15 °	1 °	0.04
300286	SL25 SXFN R P ^a 22	32	30	18.3	22 IR N60	IS M4.5x12.0	IA22	HS M3x6	15 °	2 °	0.04
300287	SL32 SXFN R P ^a 16	37	28	19.7	16 IR AG60	IS M3.5x10.0	IA16	HS M3x6	15 °	1 °	0.07
300288	SL32 SXFN R CP ^b 22	39	32	21.7	22 IR N60	IS M4.5x12.0	IA22	HS M3x6	15 °	2 °	0.07
300289	SL40 SXFN R CP ^b 16	45	28	23.7	16 IR AG60	IS M3.5x10.0	IA16	HS M3x6	15 °	1 °	0.14
300290	SL40 SXFN R CP ^b 22	47	30	25.7	22 IR N60	IS M4.5x12.0	IA22	HS M3x6	15 °	2 °	0.14
300291	SL40 SXFN R CP ^b 27	48	35	26.8	27 IR Q60	IS M5.0x18.0	IA27	HS M4x9	15 °	2.5 °	0.14

a - P - Peripheral coolant works for SL connection with 3C

b - CP - Central and Peripheral coolant works with SL connection with both 1C and 3C

c - Product on request.

All cutter heads are delivered with the insert clamp screw and torx key

Inserts are sold in packages of 10 pcs.

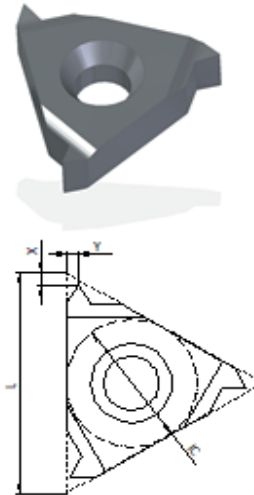
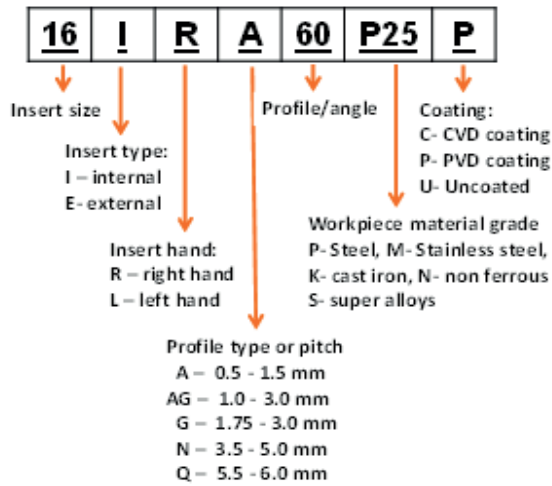

Left

Part Number	Type	Pitch mm (TPI)	IC	L	X	Y
300297	11 IL A60 P25P	0.5-1.5 (48-16)	6.350	11	0.8	0.9
300298	16 IL A60 P25P	0.5-1.5 (48-16)	9.525	16	0.8	0.9
300299	16 IL G60 P25P	1.75-3.0 (14-8)	9.525	16	1.2	1.7
300300	16 IL AG60 P25P	1.0-3.0 (26-8)	9.525	16	1.2	1.7
300301	22 IL N60 P25P	3.5-5.0 (7-5)	12.7	22	1.7	2.5
300302	27 IL Q60 P25P	5.5-6.0 (4.5-4)	15.875	27	2.1	3.1

Right

300303	11 IR A60 P25P	0.5-1.5 (48-16)	6.350	11	0.8	0.9
300304	16 IR A60 P25P	0.5-1.5 (48-16)	9.525	16	0.8	0.9
300305	16 IR G60 P25P	1.75-3.0 (14-8)	9.525	16	1.2	1.7
300306	16 IR AG60 P25P	1.0-3.0 (26-8)	9.525	16	1.2	1.7
300307	22 IR N60 P25P	3.5-5.0 (7-5)	12.7	22	1.7	2.5
300308	27 IR Q60 P25P	5.5-6.0 (4.5-4)	15.875	27	2.1	3.1
Other full profile inserts, with different standards are available upon request.						

End effectors – Grooving

KIGBA for GBA43 insert

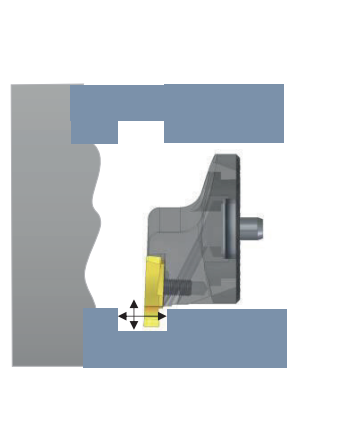
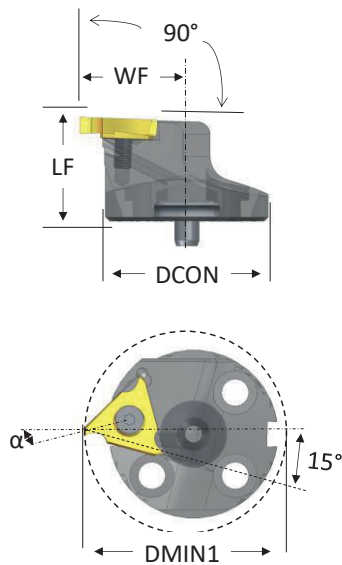

P – Peripheral coolant

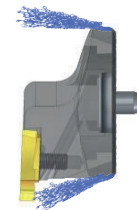

CP – Central and Peripheral coolant

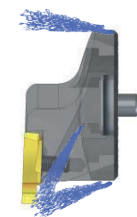

Part Number	Type	DMIN1 (mm)	LF (mm)	WF (mm)	Master insert	Insert screw	KG
300699	SL40 KIGBA R CP ^a GBA43	50	25	27	GBA43 L	IS M4.5x12	0.12
301169	SL40 KIGBA L CP ^a GBA43 ^b	50	25	27	GBA43 R	IS M4.5x12	0.12
<p>a - Product available after 2024-April</p> <p>b - CP -Central and Peripheral coolant works with SL connection with both 1C and 3C</p> <p>All cutter heads are delivered with the insert clamp screw and torx key</p>							

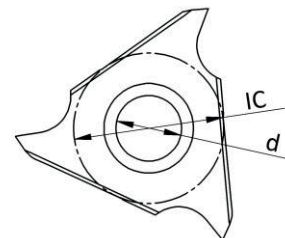
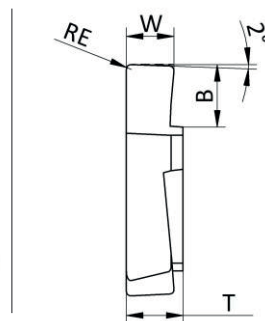

Part Number	Insert Type	IC	d	T	W	B	RE
301170	GBA43 R 100-010 P25C ^a	12.7	5.5	4.76	1.00	2.6	0.10
301171	GBA43 R 200-010 P25C ^a	12.7	5.5	4.76	2.00	4.1	0.10
301172	GBA43 R 300-010 P25C ^a	12.7	5.5	4.76	3.00	4.1	0.10
301173	GBA43 R 400-010 P25C ^a	12.7	5.5	4.76	4.00	5.2	0.10
301174	GBA43 L 100-010 P25C ^a	12.7	5.5	4.76	1.00	2.6	0.10
301175	GBA43 L 200-010 P25C ^a	12.7	5.5	4.76	2.00	4.1	0.10
301176	GBA43 L 300-010 P25C ^a	12.7	5.5	4.76	3.00	4.1	0.10
301177	GBA43 L 400-010 P25C ^a	12.7	5.5	4.76	4.00	5.2	0.10
<p>^a Order KIG oriented product, 10 pcs/package, 2 weeks delivery time</p>							

End effectors – SL blanks

SL blanks Left hand

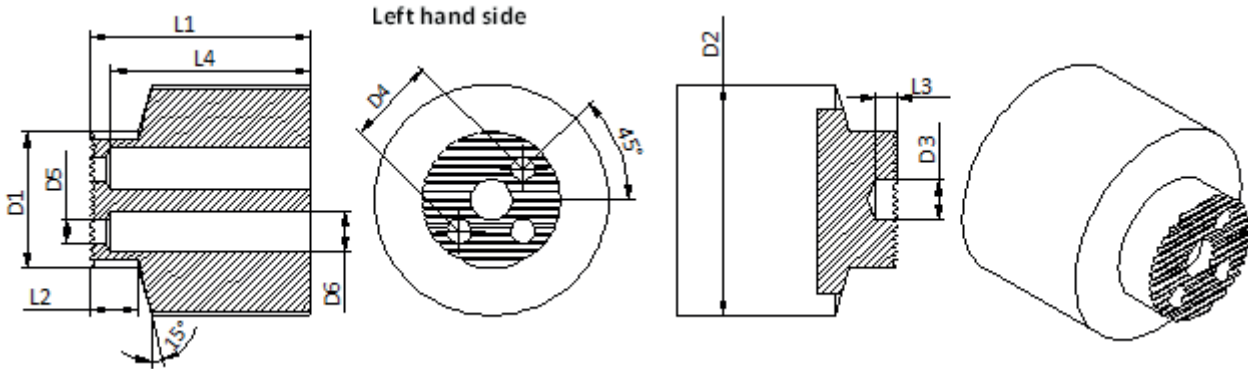

Left

Part Number	Type	D1 (mm)	D2 (mm)	D3 (mm)	D4 (mm)	D5 (mm)	D6 (mm)	L1 (mm)	L2 (mm)	L3 (mm)	L4 (mm)
300140	SL12-20-20 L	12	20	4	7.4	2.5	4	20	7	3	17
300142	SL16-26-25 L	16	26	4	9.5	3.5	6	25	7	3	22
300144	SL20-34-32 L	20	34	6	13	3.5	6	32	7	3	29
300146	SL25-40-40 L	25	40	6	16	4.5	7.5	40	7	3	37
300148	SL32-50-50 L	32	50	6	22	5.5	9	50	11	3	47
300150	SL40-60-60 L	40	60	6	28	6.5	10.5	60	11	3	57
300152	SL50-70-70 L	50	70	8	35	8.5	13.5	70	11	4	67

all SL blank parts will be supplied with a centering pin equivalent to the dimension

SL blanks Right hand

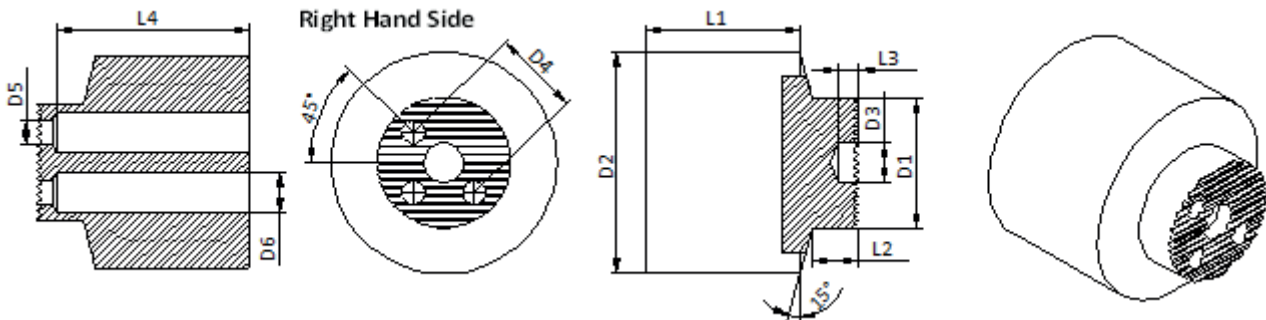

Right

Part Number	Type	D1 (mm)	D2 (mm)	D3 (mm)	D4 (mm)	D5 (mm)	D6 (mm)	L1 (mm)	L2 (mm)	L3 (mm)	L4 (mm)
300139	SL12-20-20 R	12	20	4	7.4	2.5	4	20	7	3	17
300141	SL16-26-25 R	16	26	4	9.5	3.5	6	25	7	3	22
300143	SL20-34-32 R	20	34	6	13	3.5	6	32	7	3	29
300145	SL25-40-40 R	25	40	6	16	4.5	7.5	40	7	3	37
300147	SL32-50-50 R	32	50	6	22	5.5	9	50	11	3	47
300149	SL40-60-60 R	40	60	6	28	6.5	10.5	60	11	3	57
300151	SL50-70-70 R	50	70	8	35	8.5	13.5	70	11	4	67

all SL blank parts will be supplied with a centering pin equivalent to the dimension

Accessories

Modular fixtures

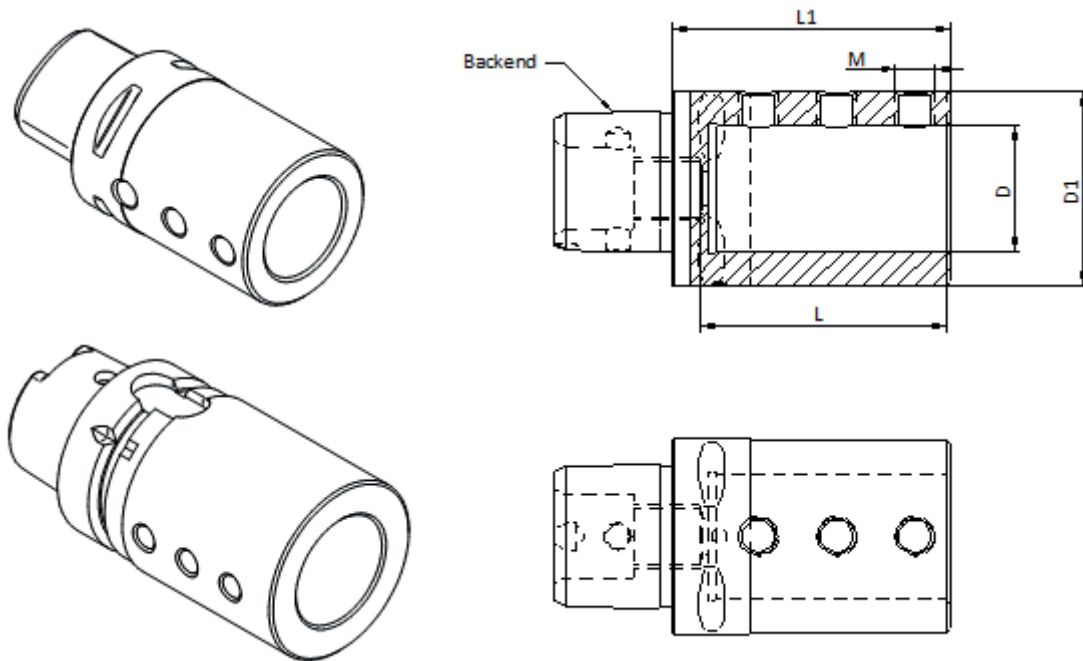

Part Number	Type	Backend	D (mm)	L (mm)	D1 (mm)	L1 (mm)	M thread
300267	PSC50-SLT32x62-71	PSC50	32	62	49.5	71	M10x1.5
300292	PSC63-SLT40x72-86	PSC63	40	72	62.5	86	M12x1.75
300293	HSK63T-SLT32x62-90	HSK63T	32	62	50	80	M10x1.5

Reduction sleeves

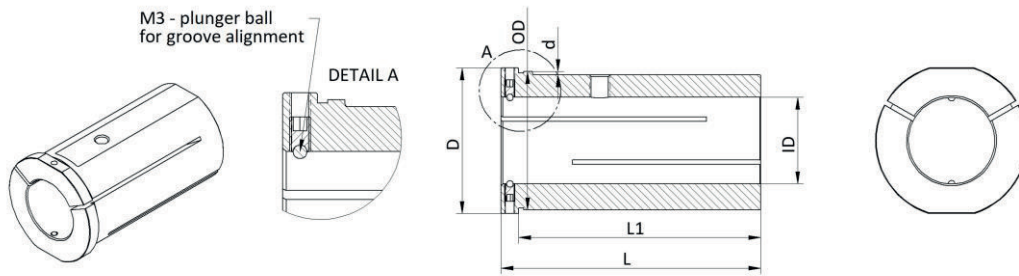

Metric

Part Number	Type	OD h6 (mm)	ID H7 (mm)	L (mm)	D (mm)	L1 (mm)	d (mm)
301180	RS 16-06	16	6	48	20	43	0.75

300606	RS 20-16	20	16	55	37	50	1
300607	RS 20-12	20	12	55	37	50	1
300608	RS 20-10	20	10	55	37	50	1
300609	RS 20-08	20	8	55	37	50	1
301179	RS 20-06	20	6	55	37	50	1

300601	RS 25-20	25	20	61	30	56	1
300602	RS 25-16	25	16	61	30	56	1
300603	RS 25-12	25	12	61	30	56	1
300604	RS 25-10	25	10	61	30	56	1
300605	RS 25-08	25	8	61	30	56	1
301178	RS 25-06	25	6	61	30	56	1

300190	RS 32-25	32	25	65	37	60	1
300191	RS 32-20	32	20	65	37	60	1
300192	RS 32-16	32	16	65	37	60	1
300193	RS 32-12	32	12	65	37	60	1
300194	RS 32-10	32	10	65	37	60	1
300600	RS 32-08	32	8	65	37	60	1
300683	RS 32-06	32	6	65	37	60	1

300163	RS 40-32	40	32	75	44	70	1.5
300164	RS 40-25	40	25	75	44	70	1.5
300165	RS 40-20	40	20	75	44	70	1.5
300166	RS 40-16	40	16	75	44	70	1.5
300167	RS 40-12	40	12	75	44	70	1.5
300168	RS 40-10	40	10	75	44	70	1.5
300599	RS 40-08	40	8	75	44	70	1.5
300682	RS 40-06	40	6	75	44	70	1.5

300455	RS 50-40	50	40	95	58	90	1
300456	RS 50-32	50	32	95	58	90	1
300457	RS 50-25	50	25	95	58	90	1

300458	RS 60-50	60	50	110	68	105	1
300459	Rs 60-40	60	40	110	68	105	1

300460	RS 80-60	80	60	128	88	123	1
300461	RS 80-50	80	50	128	88	123	1

Inch

Part Number	Type	OD h6 (inch)	ID H7 (inch)	L (inch)	D (inch)	L1 (inch)	d (inch)
300229	RS i 1 ½ - 1 ¼	1.50	1.25	2.95	1.69	2.76	0.06
300230	RS i 1 ½ - 1	1.50	1.00	2.95	1.65	2.76	0.06
300231	RS i 1 ½ - ¾	1.50	0.75	2.95	1.65	2.76	0.06
300232	RS i 1 ½ - ⅝	1.50	0.625	2.95	1.65	2.76	0.06
300233	RS i 1 ½ - ½	1.50	0.50	2.95	1.65	2.76	0.06
300234	RS i 1 ½ - ⅜	1.50	0.375	2.95	1.65	2.76	0.06
300635	RS i 1 ½ - ⅝ ₁₆	1.50	0.3125	2.95	1.65	2.76	0.06

300235	RS i 1 ¼ - 1	1.25	1.00	2.56	1.46	2.36	0.04
300236	RS i 1 ¼ - ¾	1.25	0.75	2.56	1.46	2.36	0.04
300237	RS i 1 ¼ - ⅝	1.25	0.625	2.56	1.46	2.36	0.04
300238	RS i 1 ¼ - ½	1.25	0.50	2.56	1.46	2.36	0.04
300239	RS i 1 ¼ - ⅜	1.25	0.375	2.56	1.46	2.36	0.04
300636	RS i 1 ¼ - ⅝ ₁₆	1.25	0.3125	2.56	1.46	2.36	0.04

300639	RS i 2 - 1 ½	2.00	1.25	3.74	2.28	3.54	0.04
300640	RS i 2 - 1 ¼	2.00	1.50	3.74	2.28	3.54	0.04
300641	RS i 2 - 1	2.00	1.00	3.74	2.28	3.54	0.04

300642	RS i 2 ½ - 2	2.50	2.00	4.33	2.67	4.13	0.04
300643	RS i 2 ½ - 1 ½	2.50	1.50	4.33	2.67	4.13	0.04

300644	RS i 3 - 2 ½	3.00	2.50	5.04	3.46	4.84	0.04
300645	RS i 3 - 2	3.00	2.00	5.04	3.46	4.84	0.04

Level Indicator/Digital protractor (angle inclinometer)



Part Number	Product	Width (mm)	Length (mm)	Height (mm)	Weight (g)	Battery	Lightning
300175	Digital protractor - Level Indicator	26	57	55	85	AA. 2 pcs	Yes

Delivered with a magnet with power of 4.8 kg for easier alignment of machining tools.

Insert screws

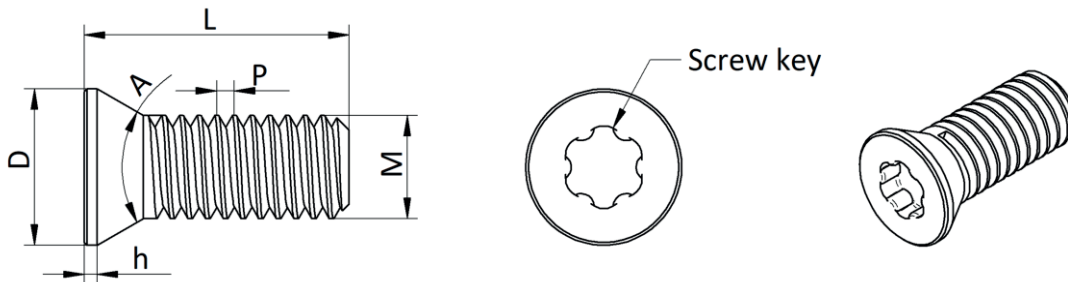

Insert screws

Part Number	Type - Torx	Quantity	Designation	Thread M	D (mm)	L (mm)	A (°)	P (mm)	h (mm)	Torx Key
300659	IS M2.0x4.0	10 pcs/bag	M2.0x4xD2.8xP0.4	M2.0	2.8	4	60	0.40	0.3	T6
300257	IS M2.2x5.0	10 pcs/bag	M2.2x5.0xD3.0xP0.45	M2.2	3.0	5.0	60	0.45	0.8	T7
300701	IS M2.5x4.5	10 pcs/bag	M2.5x4.5xD3.6xP0.45	M2.5	3.6	4.5	55	0.45	0.6	T8
300258	IS M2.5x6.0	10 pcs/bag	M2.5x6.0xD3.6xP0.45	M2.5	3.6	6.0	55	0.45	0.6	T8
300620	IS M2.5x8.0	10 pcs/bag	M2.5x8.0xD3.6xP0.45	M2.5	3.6	8.0	55	0.45	0.6	T8
300617	IS M3.5x11.0	10 pcs/bag	M3.5x11.0xD5.3xP0.60	M3.5	5.3	10.0	60	0.60	1.2	T15
300618	IS M4.0x15.0	10 pcs/bag	M4.0x15.0xD7.0xP0.70	M4.0	7.0	15.0	60	0.70	NA	T15
300619	IS M4.5x12.0	10 pcs/bag	M4.5x12.0xD6.8xP0.75	M4.5	6,8	12	60	0.75	NA	T20
300425	IS M5.0x18.0	10 pcs/bag	M5.0x18.0xD8.2xP0.8	M5.0	8,2	18	60	0.80	NA	T20

Cutter head screws

Standard: DIN 912

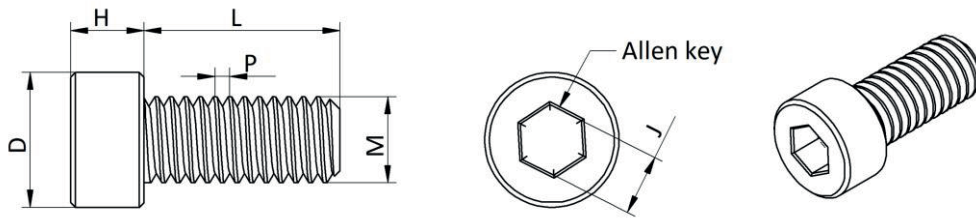

Cutter head screws

Part Number	Type (DIN912)	Quantity	Thread M	D (mm)	L (mm)	H (mm)	P (mm)	Key (mm)	Suitable for
300260	HS M2x8	10 pcs/bag	M2	3.8	8	2	0.4	Allen key A/F 1.5	SL12
300261	HS M2x14	10 pcs/bag	M2	3.8	14	2	0.4	Allen key A/F 1.5	SL12
300673	HS M3x6	10 pcs/bag	M3	5.5	6	3	0.5	Allen key A/F 2.5	EA16, IA16, EA22, IA22
300169	HS M3x8	10 pcs/bag	M3	5.5	8	3	0.5	Allen key A/F 2.5	SL16, SL20
300170	HS M4x9	10 pcs/bag	M4	7	9	4	0.7	Allen key A/F 3	SL25
300171	HS M5x12	10 pcs/bag	M5	8.5	12	5	0.8	Allen key A/F 4	SL32
300262	HS M6x14	10 pcs/bag	M6	10	14	6	1	Allen key A/F 5	SL40
300263	HS M8x14	10 pcs/bag	M8	13	14	8	1.25	Allen key A/F 6	SL50, SL60

Shims

Part Number	Type	Fits
300433	Shim CCMT 09T3	STMD M32-256 SCLCL/R C, STMD M40-320 SCLCL/R C
300430	Shim CCMT 1204	SL40 SCLCL/R CP
300431	Shim DCMT 11T3	SL40 SDUCL/R CP
300432	Shim TCMT 16T3	SL40 STFCL/R CP
300669	Shim VCMT 1604	SL40 SVUCL/R CP, SL32 SVUCL/R CP
300435	Shim EA16 - IL16	SL25 SXFNL P 16, SL32 SXFNL P 16, SL40 SXFNL CP 16
300436	Shim IA16 - IR16	SL25 SXFNR P 16, SL32 SXFNR P 16, SL40 SXFNR CP 16
300437	Shim EA22 - IL22	SL25 SXFNL P 22, SL32 SXFNL CP 22, SL40 SXFNL CP 22
300438	Shim IA22 - IR22	SL25 SXFNR P 22, SL32 SXFNR CP 22, SL40 SXFNR CP 22
300439	Shim EA27 - IL27	SL40 SXFNL CP 27
300440	Shim IA27 - IR27	SL40 SXFNR CP 27

Service kit for P clamp heads (includes level, shim, slot screw, spring)

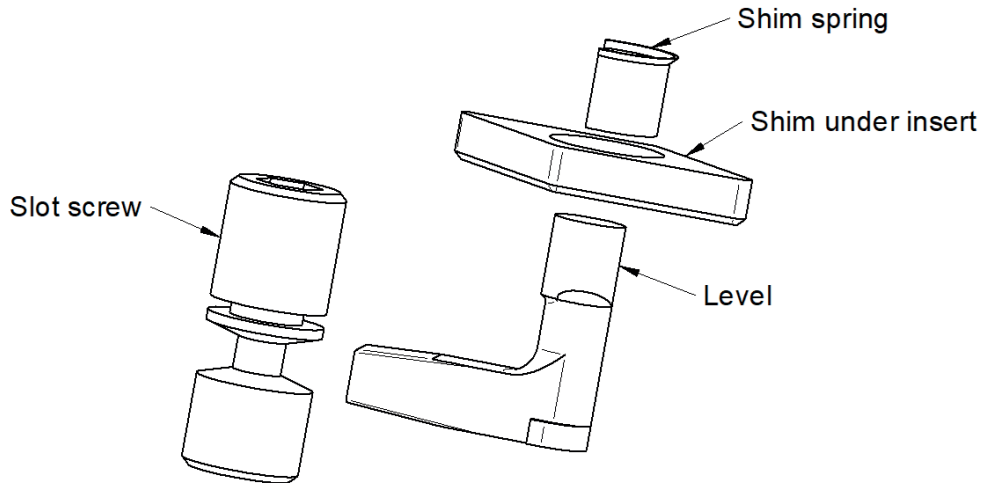

Part number	Service kit for	Cutter head	Level, 1 pcs	Shim, 1 pcs	Slot screw, 1 pcs	Spring, 1 pcs
300434	300086 300402	SL40 PDUNR CP SL40 PDUNL CP	LV4 G0516	Shim DNMG 1506	M8x1x21	T2-6
300426	300427 300562	SL32 PDUNR CP SL32 PDUNL CP	LV3 G0312	Shim DNMG 1104	M6x1x17	T1-5
301165	300661 300660	SL25 PDUNR CP SL25 PDUNL CP	LV3 G0310	Shim DNMG 1104	M5x0.8x15	T1-5
300471	300088 300403 300429 300563	SL40 PTFNR CP SL40 PTFNL CP SL32 PTFNR CP SL32 PTFNL CP	LV3 G0310	Shim TNMG 1604	M6x1x17	T1-5
300472	300087 300404	SL40 PCLNR CP SL40 PCLNL CP	LV4 G0513	Shim CNMG 1204	M8x1x21	T2-6
300473	300428 300564	SL32 PCLNR CP SL32 PCLNL CP	LV4 G0513	Shim CNMG 1204	M6x1x17	T2-6
300668	300474 300475	SL40 PWLNR CP SL40 PWLNL CP	LV4 G0513	Shim WNMG 0804	M8x1x21	T2-6

Coolant adapters for steel bars

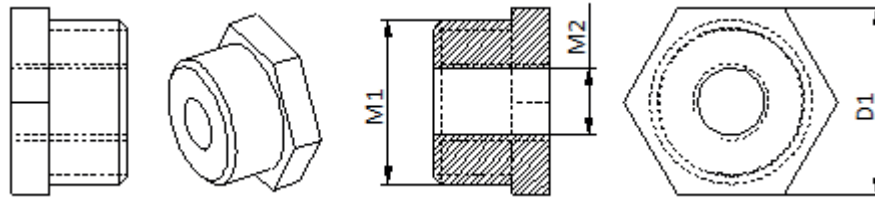

Steel bars

Part Number	Type	M1	M2	D1
300610	CA G ¼ - G ⅛	G ¼	G ⅛	17
300611	CA G ½ - G ¼	G ½	G ¼	24
300612	CA G ¾ - G ¼	G ¾	G ¼	30

Coolant adapters for carbide bars

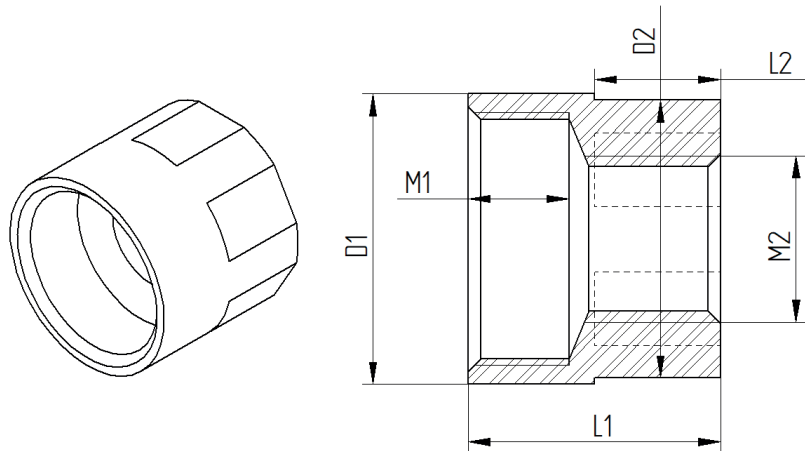

Carbide bars

Part Number	Type	M1	M2	L1	L2	D1	D2	Works for
300613	CA M12x1 G ⅝	M12x1	G ⅝	16	8	14	13	STMD M16-204 SL16, STMD M16-268 SL16 STMD I 5/8-8.0 SL16, STMD I 5/8-10.6 SL16
300614	CA M16x1 G ¾	M16x1	G ¾	20	10	18	16	STMD M20-260 SL20, STMD M20-340 SL20 STMD I 3/4-10.3 SL20, STMD I 3/4-13.4 SL20
300615	CA M20x1 G ¾	M20x1	G ¾	20	10	23	22	STMD M25-340 SL25, STMD I 1-16.9 SL25
300616	CA M24x1 G ¾	M24x1	G ¾	30	15	30	28	STMD M32-544 SL32, STMD I 1 1/4 -21.4 SL32

MAQ Master Inserts

Inserts are sold in packages of 10 pcs.

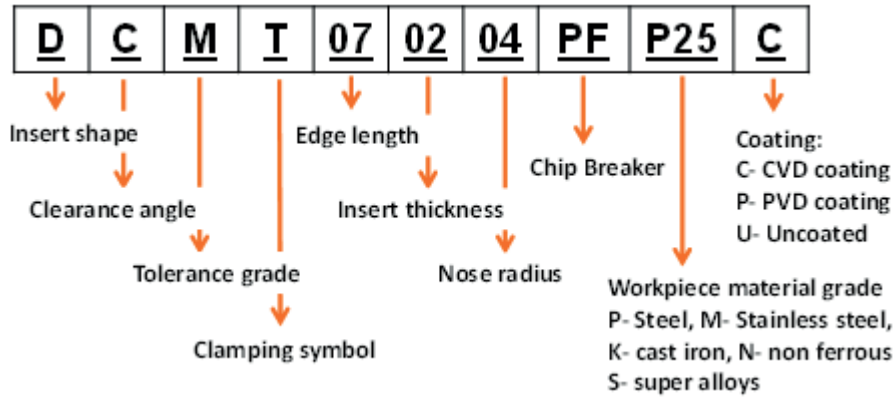

Positive insert

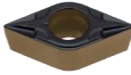
Part Number	Article	DCMT
300244	DCMT 070204-FP P25C	
300245	DCMT 11T304-FP P25C	

Part Number	Article	TCMT
300246	TCMT 090204-FP P25C	
300247	TCMT 110304-FP P25C	
300248	TCMT 16T304-FP P25C	

Part Number	Article	CCMT
300249	CCMT 060204-FP P25C	
300250	CCMT 09T304-FP P25C	
300251	CCMT 120404-FP P25C	

Negative insert

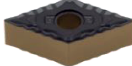
Part Number	Article	DNMG
300294	DNMG 150604-LC P25C	

Part Number	Article	TNMG
300295	TNMG 160404-LC P25C	

Part Number	Article	CNMG
300296	CNMG 120404 LC P25C	

FISSAGGIO DELLE BARRE ANTIVIBRANTI

Un bloccaggio inadeguato con una bassa rigidità alla flessione avrà un impatto negativo sulle prestazioni.

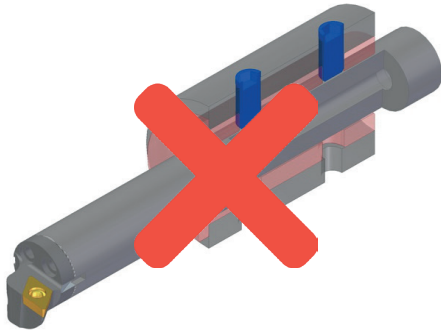

SERRAGGIO DIRETTO A VITE

- Rigidità finale inaccettabile
- Lunghezza di serraggio = NON APPLICABILE
- Non utilizzare su barre MAQ

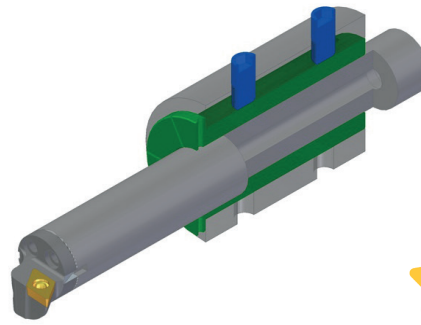

SERRAGGIO VITE + BUSSOLA

- Rigidità finale accettabile per basse sporgenze
- Lunghezza di serraggio consigliata minimo 3XD

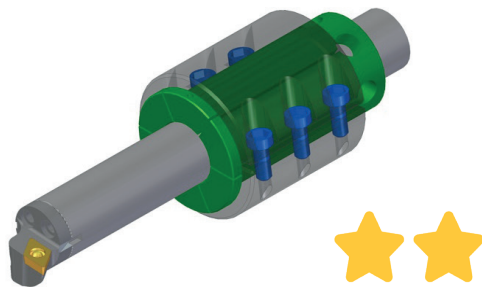

SERRAGGIO ELASTICO+BUSSOLA

- Buona rigidità alla flessione
- Lunghezza di serraggio consigliata minimo 3XD

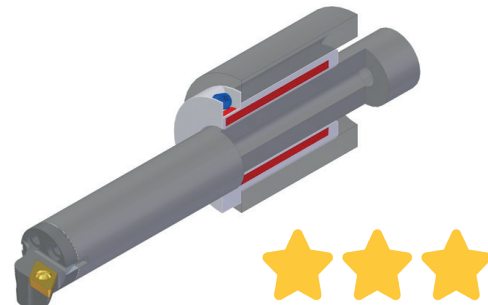

SERRAGGIO IDRAULICO

- Ottima rigidità alla flessione consigliato per elevate sporgenze
- Lunghezza di serraggio consigliata minimo 2XD

BUSSOLA DI RIDUZIONE

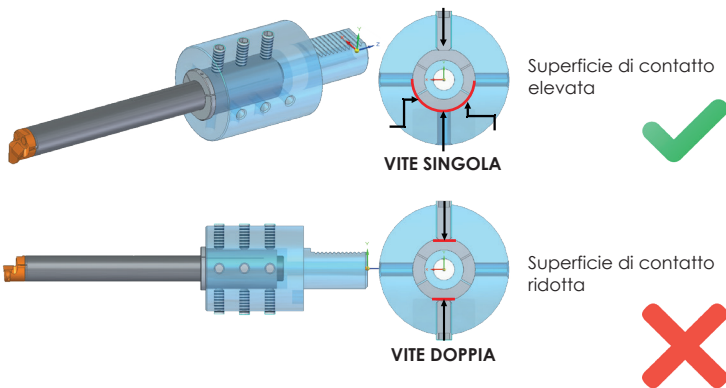

PREFERIRE PORTAUTENSILI CON SEZIONI ELEVATE

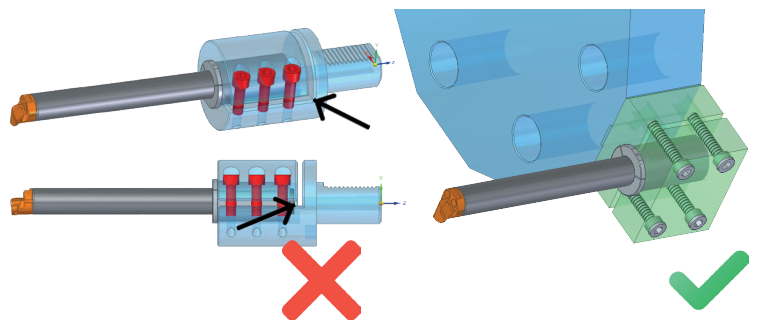

ATTACCHI MACCHINA

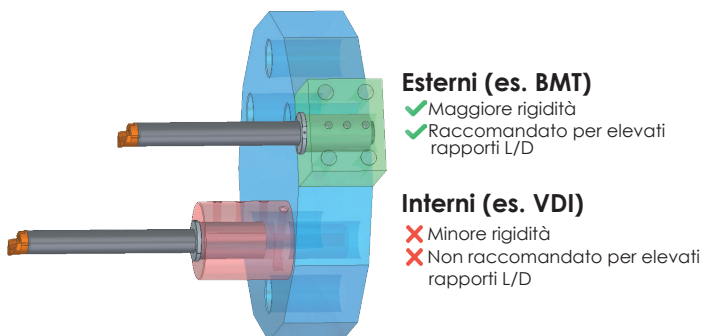

RIDURRE GLI SBALZI

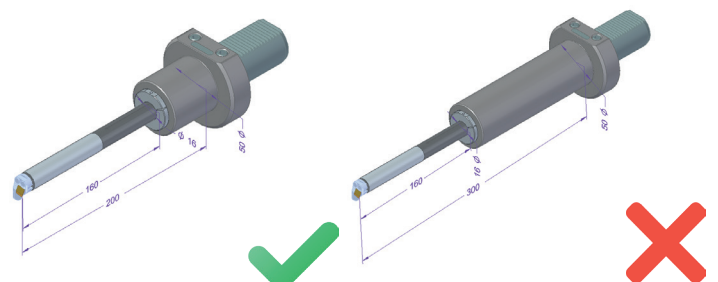

M A



apm-trade

ALUISIO PIETRO & C. S.n.c

P.IVA/VAT N°: IT03878540263

 VIA A. DIAZ, 7 - 31046 ODERZO (TV) - ITALY

 PIETRO +39 3487155749

 MICHELE +39 3495253257

 aluisio.snc@gmail.com

