



apm-trade

**BARRE ANTIVIBRANTI
PER TORNITURA
ICTM ISO12164-3**

HSK-T

MAQ 

Simplify Machining™

Tecnologia per eliminare
le vibrazioni nelle lavorazioni
meccaniche.

Utensili brevettati:

- Autoregistranti
- Plug & Play
- Senza manutenzione



SISTEMA PLUG AND PLAY VIBRATION FREE

Durante le lavorazioni meccaniche, sia con sporgenze elevate (11-15xD), che ridotte (3-6xD) si generano delle vibrazioni con:

- danneggiamento di pezzi e superfici
- scheggiatura e rottura degli inserti da taglio
- aumento dei costi di produzione.

Il sistema **MAQ** NEUTRALIZZA LE VIBRAZIONI degli utensili.

La frequenza delle vibrazioni varia per il consumo degli inserti, per i diversi tipi di materiale lavorato ed i parametri macchina utilizzati.

Privo di regolazioni, Il sistema **MAQ** SI ADATTA AUTOMATICAMENTE a tutte le condizioni di lavoro garantendo:

- riduzione dei tempi di lavoro
- miglioramento della qualità delle superfici
- diminuzione delle tolleranze
- elevata ripetibilità dei processi.



BARRE ANTIVIBRANTI

4a GENERAZIONE

Anelli di gomma con olio smorzante

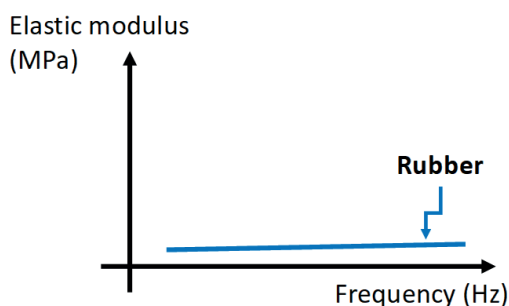
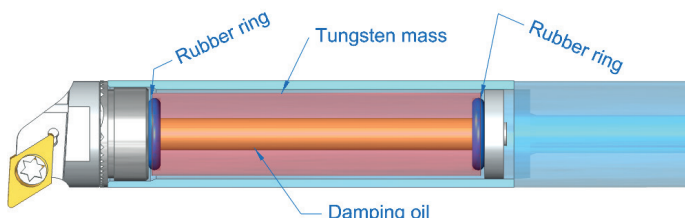

5A GENERAZIONE MAQ

Polimeri con rigidità dipendente dalla frequenza

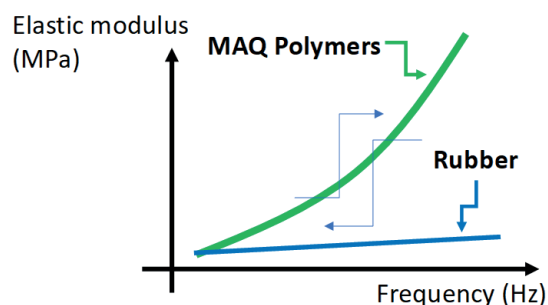
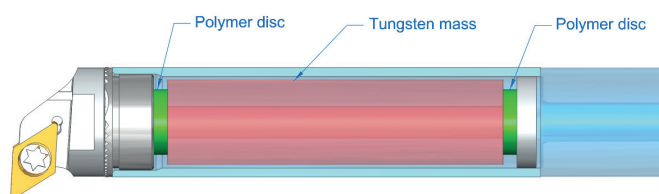

Turning – Multitask with modular backends.

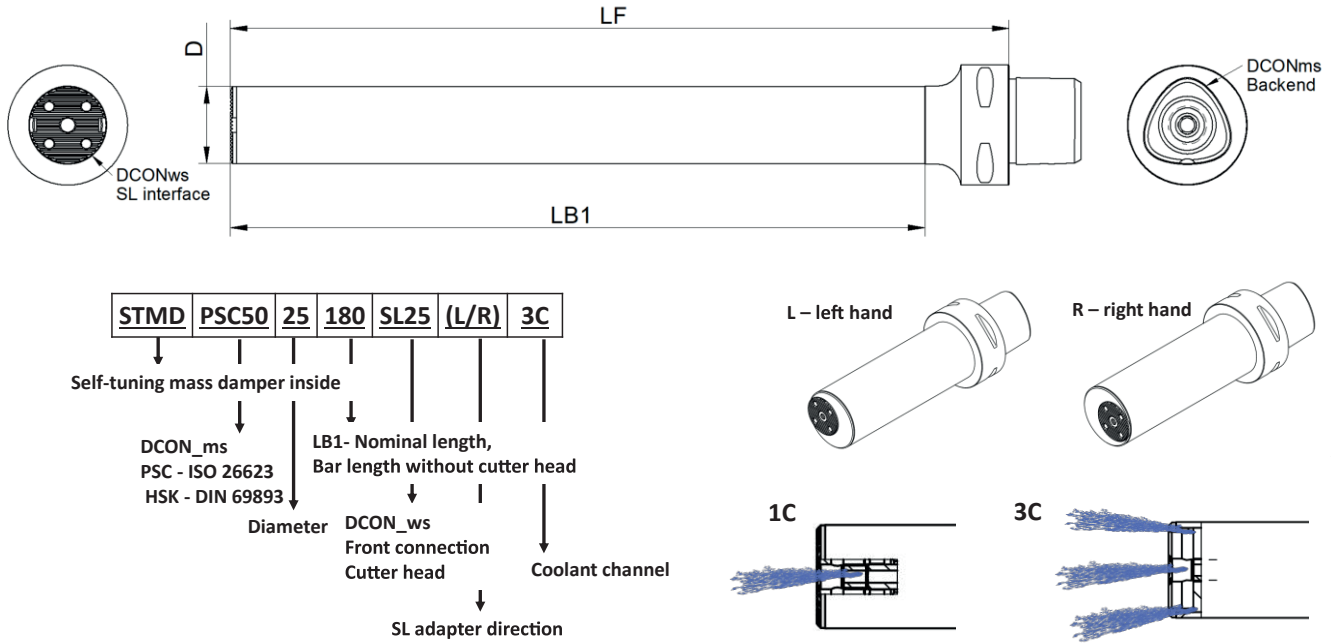

Standard: HSK63T (with SL interface and exchangeable heads)

Standard: HSK63T (with SL interface and exchangeable heads)										
Part number	Type	Backend	D (mm)	Dmin (mm) ^d	LF (mm)	LB1 (mm)	Screws	Material	KG	
300532	STMD HSK63T 16-064 SL16 3C	HSK63	16	20	120	64	M3X8	Steel	1.0	
300533	STMD HSK63T 16-096 SL16 3C	HSK63	16	20	152	96	M3X8	Steel	1.2	
300534	STMD HSK63T 20-090 SL20 3C	HSK63	20	25	146	90	M3X8	Steel	1.0	
300535	STMD HSK63T 20-130 SL20 3C	HSK63	20	25	186	130	M3X8	Steel	1.2	
300536	STMD HSK63T 25-130 SL25 3C	HSK63	25	32	186	130	M4X9	Steel	1.5	
300537	STMD HSK63T 25-180 SL25 3C	HSK63	25	32	236	180	M4X9	Steel	1.6	
300538	STMD HSK63T 25-230 SL25 3C	HSK63	25	32	286	230	M4X9	Steel	1.7	
300539	STMD HSK63T 32-170 SL32 3C	HSK63	32	40	226	170	M5X12	Steel	1.8	
300540	STMD HSK63T 32-230 SL32 3C	HSK63	32	40	286	230	M5X12	Steel	2.2	
300541	STMD HSK63T 32-294 SL32 3C	HSK63	32	40	350	294	M5X12	Steel	2.7	
300542	STMD HSK63T 40-210 SL40 3C	HSK63	40	50	266	210	M6X14	Steel	2.6	
300543	STMD HSK63T 40-290 SL40 3C	HSK63	40	50	346	290	M6x14	Steel	3.9	
300544	STMD HSK63T 40-370 SL40 3C ^a	HSK63	40	50	426	370	M6x14	Steel	4.2	

^d - estimated with using standard SDUCR cutter heads from MAQ.

Burnishing

Diamond burnishing Right hand

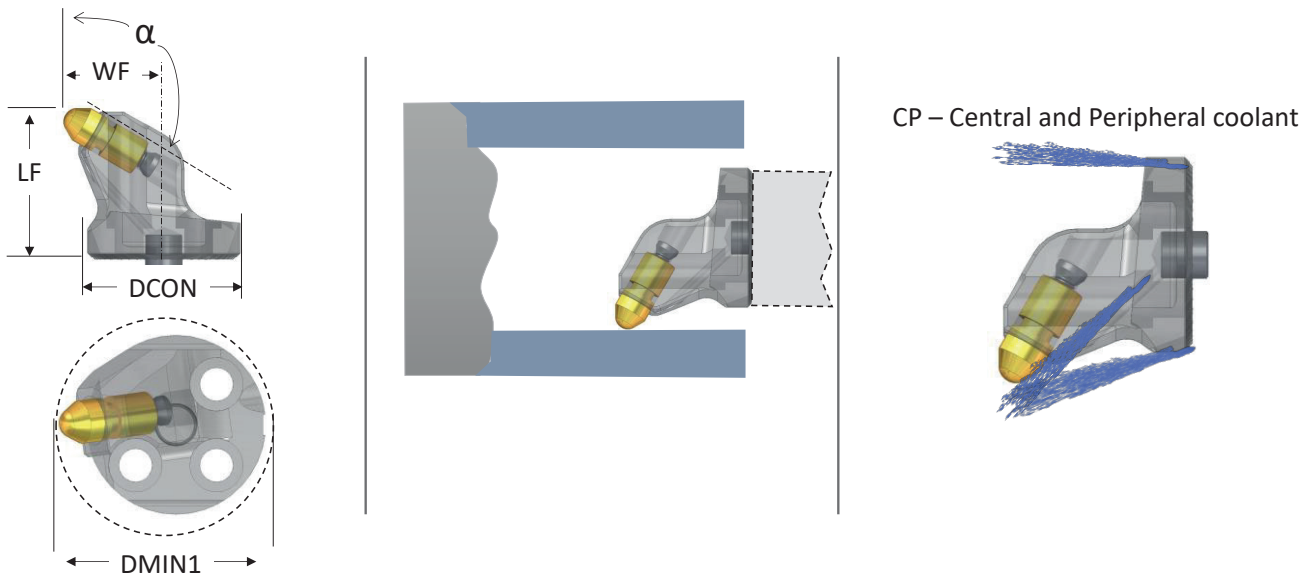

Part Number	Type	DCON (mm)	DMIN1 (mm)	LF (mm)	WF (mm)	α (°)	Burnishing Nib	Nib screw	KG
300631	SL20 DB CP	SL 20	24	21	12	30	R 061402	IS M3x7	0.02
300632	SL25 DB CP	SL 25	30	25	16	30	R 061402	IS M3x7	0.04
300633	SL32 DB CP	SL 32	38	33	20	30	R 061402	IS M3x7	0.07
300634	SL40 DB CP	SL 40	43	34	24	30	R 061402	IS M3x7	0.14

All burnishing heads are delivered with the burnishing nib and nib screw.

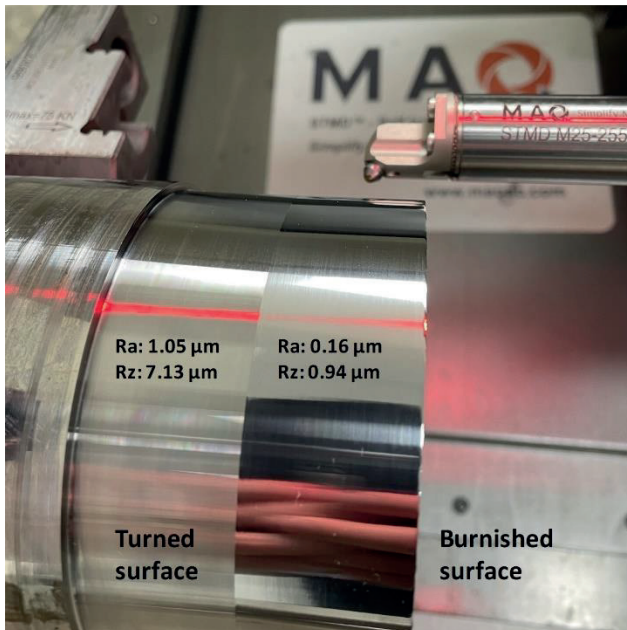

Mirror surface finish in one pass, up to 15xD!

The MAQ diamond burnishing tool works on carbon steel, tool steel, cast iron, ferrous and non-ferrous (P, M, K, N, S) materials.

Suggested starting machining parameter to all materials:

- Interference with workpiece material 0.05-0.2 mm (0.002-0.003 inch)
- Cutting speed 60-230 m/min (200-750 SFM)
- Feed rate 0.08-0.15 mm/rev (0.003-0.006 IPR)

We recommend a feed rate at 70% of the feed rate in previous turning operation.

We recommend start with interference of 0.1 mm (0.004 µinch) and increase the interference if the surface finish is not reached.

Recommended surface finish prior burnishing operation is $Ra < 1.6 \mu\text{m}$ (64 µinch). After burnishing, the surface finish can normally reach $Ra < 0.3 \mu\text{m}$.

Diamond burnishing works well on STMD tools and can reach mirror surface finish up to **15xD** setup.

Note: diamond burnishing normally has negligible impact on the size of the bore. A typical bore size change in burnishing of high alloy steel 4340 is within 10-15 µm (0.0004-0.0006 inch).

End-effecters

SDUCR, SDUCL for DCMT Inserts

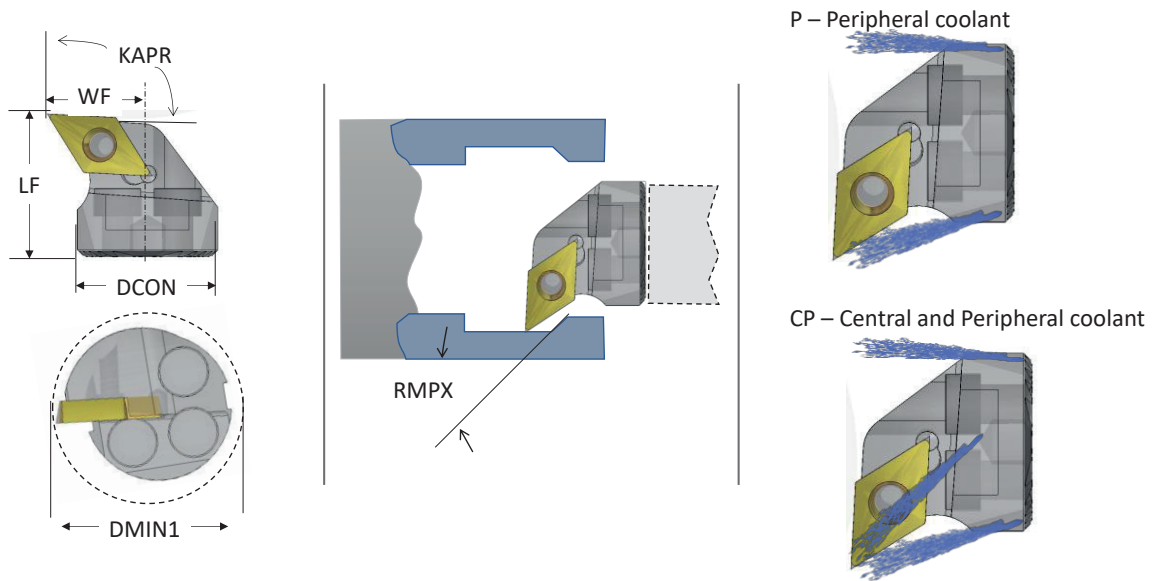

Part Number	Type	DMIN1 (mm)	LF (mm)	WF (mm)	KAPR (°)	RMPX (°)	Master insert	Insert screw	KG
300118	SL12 SDUCL P ^a	16	14	9	93	30	DCMT 070204	IS M2.5x6.0	0.01
300059	SL12 SDUCR P ^a	16	14	9	93	30	DCMT 070204	IS M2.5x6.0	0.01
300119	SL16 SDUCL P ^a	20	16	11	93	30	DCMT 070204	IS M2.5x6.0	0.01
300060	SL16 SDUCR P ^a	20	16	11	93	30	DCMT 070204	IS M2.5x6.0	0.01
300120	SL20 SDUCL P ^a	25	20	13	93	30	DCMT 11T304	IS M3.5x10.0	0.02
300061	SL20 SDUCR P ^a	25	20	13	93	30	DCMT 11T304	IS M3.5x10.0	0.02
300121	SL25 SDUCL P ^a	32	22	17	93	30	DCMT 11T304	IS M3.5x10.0	0.04
300062	SL25 SDUCR P ^a	32	22	17	93	30	DCMT 11T304	IS M3.5x10.0	0.04
300122	SL32 SDUCL P ^a	40	27	22	93	30	DCMT 11T304	IS M3.5x10.0	0.07
300063	SL32 SDUCR P ^a	40	27	22	93	30	DCMT 11T304	IS M3.5x10.0	0.07
300064	SL40 SDUCR P ^a	50	32	27	93	30	DCMT 11T304	IS M3.5x10.0	0.14
300209	SL40 SDUCL CP ^b	50	32	27	93	30	DCMT 11T304	IS M3.5x10.0	0.14
300195	SL40 SDUCR CP ^b	50	32	27	93	30	DCMT 11T304	IS M3.5x10.0	0.14

All cutter heads are delivered with the insert clamp screw and torx key

a - P - Peripheral coolant works for SL connection with 3C

b - CP - Central and Peripheral coolant works with SL connection with both 1C and 3C

SDQCR for DCMT Inserts

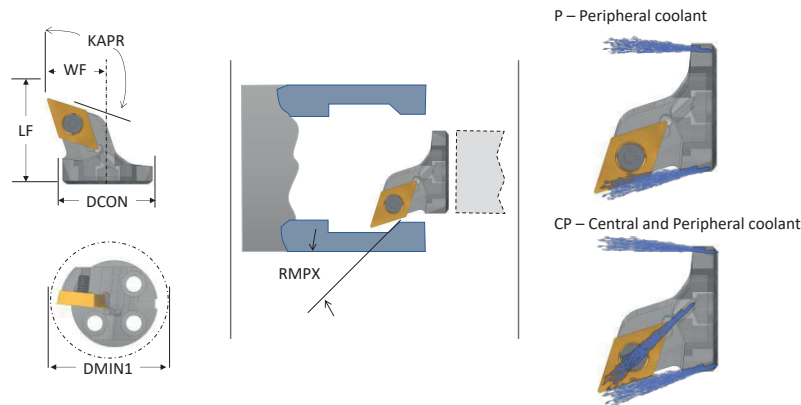

Part Number	Type	DMIN1 (mm)	LF (mm)	WF (mm)	KAPR (°)	RMPX (°)	Master insert	Insert screw	KG
300545	SL16 SDQCR P ^a	20	18	11	107.5	17	DCMT 070204	IS M2.5x6.0	0.01
300546	SL20 SDQCR CP ^b	25	24	13	107.5	17	DCMT 11T304	IS M3.5x10.0	0.02
300547	SL25 SDQCR CP ^b	32	24	17	107.5	17	DCMT 11T304	IS M3.5x10.0	0.04
300548	SL32 SDQCR CP ^b	40	26	22	107.5	17	DCMT 11T304	IS M3.5x10.0	0.07
300549	SL40 SDQCR CP ^b	50	26	27	107.5	17	DCMT 11T304	IS M3.5x10.0	0.14

All cutter heads are delivered with the insert clamp screw and torx key
a - P - Peripheral coolant works for SL connection with 3C
b - CP -Central and Peripheral coolant works with SL connection with both 1C and 3C

SDXCR for DCMT Inserts

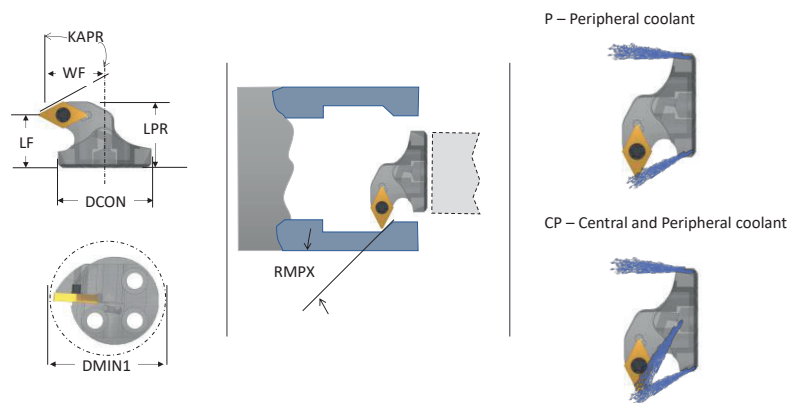

Part Number	Type	DMIN1 (mm)	LF (mm)	LPR (mm)	WF (mm)	KAPR (°)	RMPX (°)	Master insert	Insert screw	KG
300550	SL16 SDXCR CP ^a	22	12.5	16	13	62.5	60	DCMT 070204	IS M2.5x6.0	0.01
300551	SL20 SDXCR CP ^b	27	13	17	15	62.5	60	DCMT 070204	IS M2.5x8.0	0.02
300552	SL25 SDXCR CP ^b	33	14	17.6	18	62.5	60	DCMT 070204	IS M2.5x8.0	0.04
300553	SL32 SDXCR CP ^b	40	17	22.5	22	62.5	60	DCMT 11T304	IS M3.5x10.0	0.07
300554	SL40 SDXCR CP ^b	50	17	22	27	62.5	60	DCMT 11T304	IS M3.5x10.0	0.14

All cutter heads are delivered with the insert clamp screw and torx key
a - P - Peripheral coolant works for SL connection with 3C
b - CP -Central and Peripheral coolant works with SL connection with both 1C and 3C

Back boring – B-SDUCR for DCMT Inserts

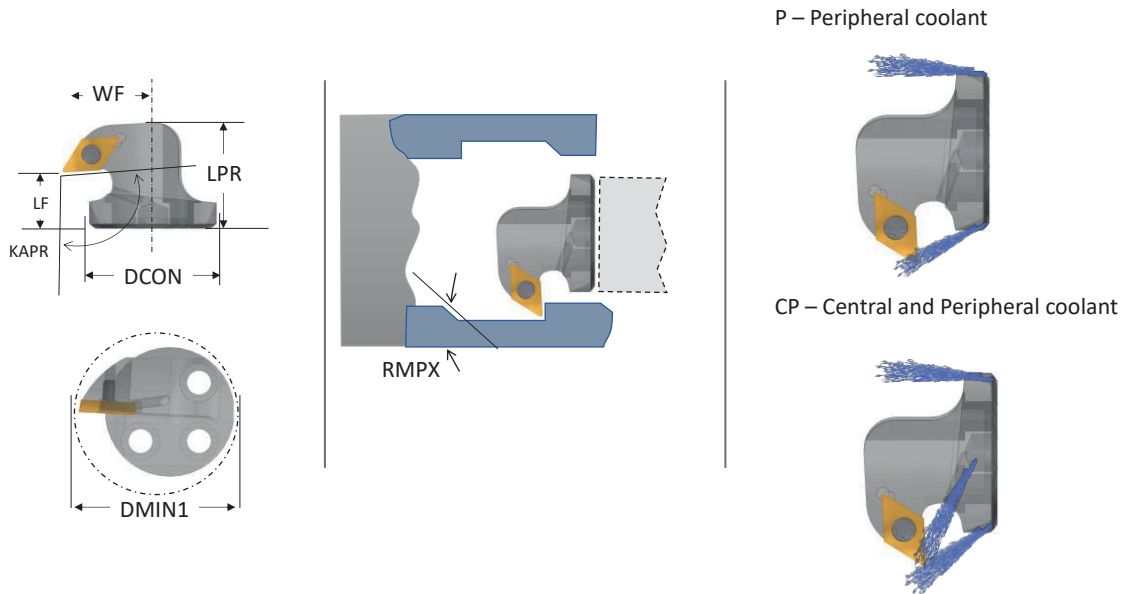

Part Number	Type	DMIN1 (mm)	LF (mm)	LPR (mm)	WF (mm)	KAPR (°)	RMPX (°)	Master insert	Insert screw	KG
300555	SL16 B-SDUCR CP ^a	20	11	20	13	93	30	DCMT 070204	IS M2.5x6.0	0.01
300556	SL20 B-SDUCR CP ^a	25	11	20	15	93	30	DCMT 070204	IS M2.5x6.0	0.02
300557	SL25 B-SDUCR CP ^a	32	11	21	18	93	30	DCMT 070204	IS M2.5x8.0	0.04
300558	SL32 B-SDUCR CP ^a	40	13	27	22	93	30	DCMT 11T304	IS M3.5x10.0	0.07
300559	SL40 B-SDUCR CP ^a	50	15	29	27	93	30	DCMT 11T304	IS M3.5x10.0	0.14

All cutter heads are delivered with the insert clamp screw and torx key
a - CP -Central and Peripheral coolant exits

STFCR, STFCL for TCMT Inserts

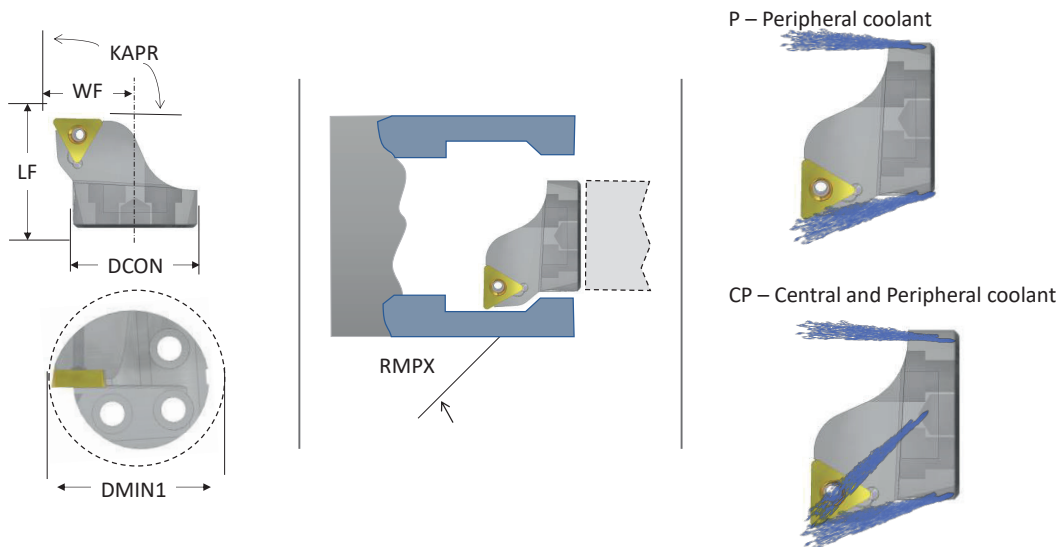

Part Number	Type	DMIN1 (mm)	LF (mm)	WF (mm)	KAPR (°)	RMPX (°)	Master insert	Insert screw	KG
300124	SL12 STFCL P ^a	16	14	9	91	NA	TCMT 090204	IS M2.2x5.0	0.01
300065	SL12 STFCR P ^a	16	14	9	91	NA	TCMT 090204	IS M2.2x5.0	0.01
300125	SL16 STFCL P ^a	20	16	11	91	NA	TCMT 090204	IS M2.2x5.0	0.01
300066	SL16 STFCR P ^a	20	16	11	91	NA	TCMT 090204	IS M2.2x5.0	0.01
300126	SL20 STFCL P ^a	25	20	13	91	NA	TCMT 110304	IS M2.5x8.0	0.02
300067	SL20 STFCR P ^a	25	20	13	91	NA	TCMT 110304	IS M2.5x8.0	0.02
300127	SL25 STFCL P ^a	32	22	17	91	NA	TCMT 110304	IS M2.5x8.0	0.04
300068	SL25 STFCR P ^a	32	22	17	91	NA	TCMT 110304	IS M2.5x8.0	0.04
300128	SL32 STFCL P ^a	40	27	22	91	NA	TCMT 16T304	IS M3.5x10.0	0.07
300069	SL32 STFCR P ^a	40	27	22	91	NA	TCMT 16T304	IS M3.5x10.0	0.07
300070	SL40 STFCR P ^a	50	32	27	91	NA	TCMT 16T304	IS M3.5x10.0	0.14
300210	SL40 STFCL CP ^b	50	32	27	91	NA	TCMT 16T304	IS M3.5x10.0	0.14
300197	SL40 STFCR CP ^b	50	32	27	91	NA	TCMT 16T304	IS M3.5x10.0	0.14

All cutter heads are delivered with the insert clamp screw and torx key

a - P - Peripheral coolant works for SL connection with 3C

b - CP - Central and Peripheral coolant works with SL connection with both 1C and 3C

STFPR for TPMT Inserts

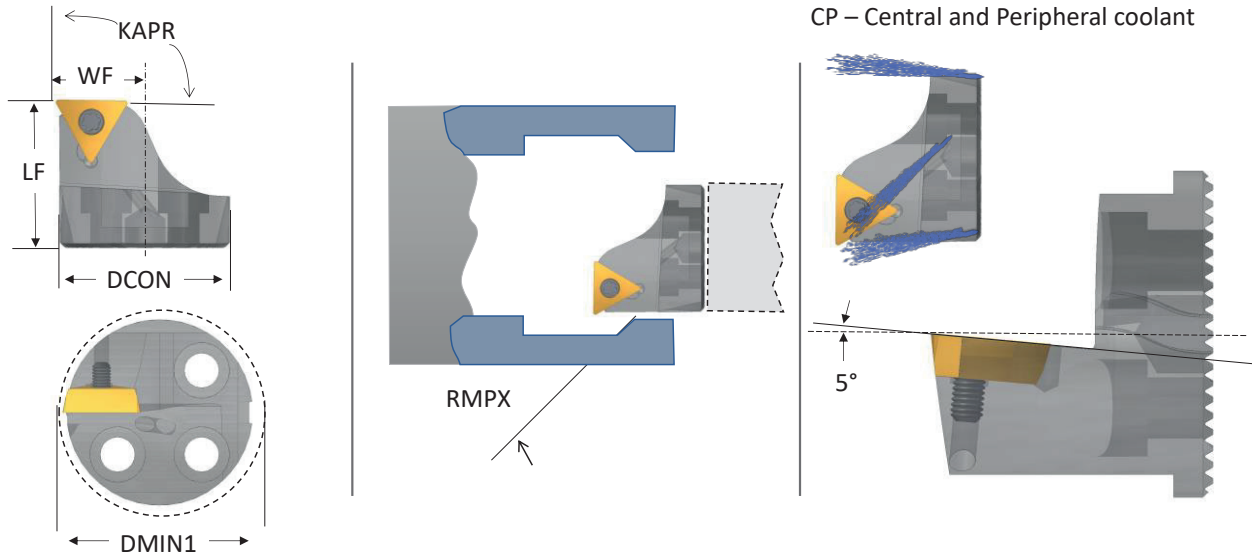

Part Number	Type	DMIN1 (mm)	LF (mm)	WF (mm)	KAPR (°)	RMPX (°)	Master insert	Insert screw	KG
300466	SL16 STFPR CP ^a	18	17	8.8	91	NA	TPMT 090204	IS M2.2x5.0	0.01
300467	SL20 STFPR CP ^a	22	19	10.8	91	NA	TPMT 110304	IS M2.5x8.0	0.02
300468	SL25 STFPR CP ^a	27	22	13.3	91	NA	TPMT 110304	IS M2.5x8.0	0.04

All cutter heads are delivered with the insert clamp screw and torx key

a - CP -Central and Peripheral coolant works with SL connection with both 1C and 3C

SCLCR, SCLCL for CCMT Inserts

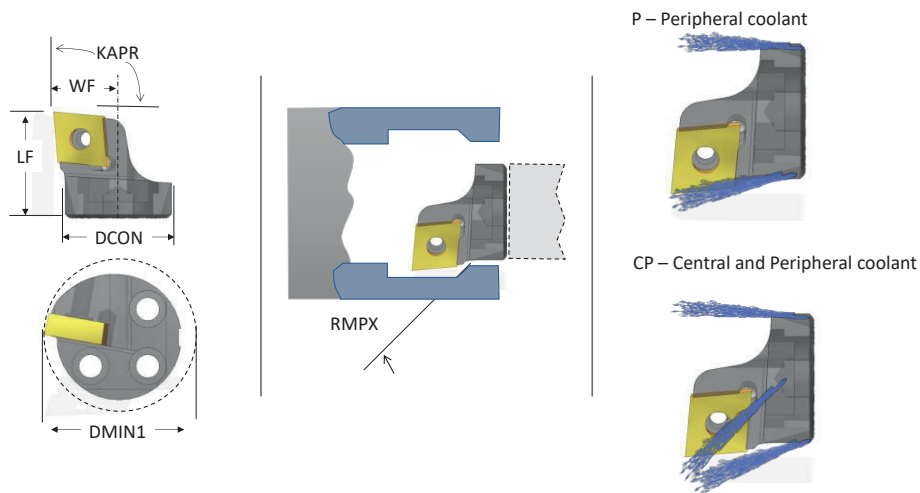

Part Number	Type	DMIN1 (mm)	LF (mm)	WF (mm)	KAPR (°)	RMPX (°)	Master Insert	Insert screw	KG
300112	SL12 SCLCL P ^a	16	14.4	10	95	NA	CCMT 060204	IS M2.5x6.0	0.01
300071	SL12 SCLCR P ^a	16	14.4	10	95	NA	CCMT 060204	IS M2.5x6.0	0.01
300113	SL16 SCLCL P ^a	20	15.4	11	95	NA	CCMT 060204	IS M2.5x6.0	0.01
300072	SL16 SCLCR P ^a	20	15.4	11	95	NA	CCMT 060204	IS M2.5x6.0	0.01
300114	SL20 SCLCL P ^a	25	19.1	13	95	NA	CCMT 09T304	IS M3.5x10.0	0.02
300073	SL20 SCLCR P ^a	25	19.1	13	95	NA	CCMT 09T304	IS M3.5x10.0	0.02
300115	SL25 SCLCL P ^a	32	21.1	17	95	NA	CCMT 09T304	IS M3.5x10.0	0.04
300074	SL25 SCLCR CP ^a	32	21.1	17	95	NA	CCMT 09T304	IS M3.5x10.0	0.04
300116	SL32 SCLCL P ^a	40	24.1	22	95	NA	CCMT 09T304	IS M3.5x10.0	0.07
300075	SL32 SCLCR P ^a	40	24.1	22	95	NA	CCMT 09T304	IS M3.5x10.0	0.07
300076	SL40 SCLCR P ^a	50	25.1	27	95	NA	CCMT 09T304	IS M3.5x10.0	0.14
300208	SL40 SCLCL CP ^b	50	25.1	27	95	NA	CCMT 120404	IS M4.0x15.0	0.14
300196	SL40 SCLCR CP ^b	50	25.1	27	95	NA	CCMT 120404	IS M4.0x15.0	0.14

All cutter heads are delivered with the insert clamp screw and torx key

a - P - Peripheral coolant works for SL connection with 3C

b - CP - Central and Peripheral coolant works with SL connection with both 1C and 3C

SVUCR, SVUCL for VCMT Inserts

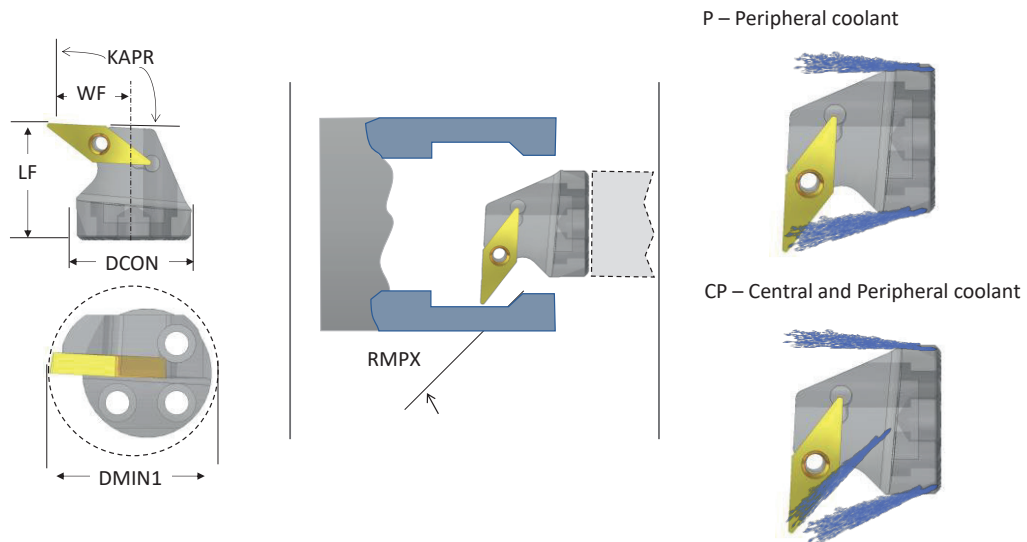

Part Number	Type	DMIN (mm)	LF (mm)	WF (mm)	KAPR (°)	RMPX (°)	Master Insert	Insert screw	KG
300666	SL16 SVUCR P ^{a,c}	25	17	16	93	45	VCMT 110304	IS M2.5x6.0	0.02
300199	SL20 SVUCL P ^a	27	20.5	15	93	45	VCMT 110304	IS M2.5x8.0	0.02
300198	SL20 SVUCR P ^a	27	20.5	15	93	45	VCMT 110304	IS M2.5x8.0	0.02
300201	SL25 SVUCL P ^a	33	20.5	18	93	45	VCMT 110304	IS M2.5x8.0	0.04
300200	SL25 SVUCR P ^a	33	20.5	18	93	45	VCMT 110304	IS M2.5x8.0	0.04
300598	SL32 SVUCL CP ^{b,c}	40	25	22	93	45	VCMT 160404	IS M3.5x10.0	0.08
300597	SL32 SVUCR CP ^b	40	25	22	93	45	VCMT 160404	IS M3.5x10.0	0.08
300560	SL40 SVUCL CP ^b	50	28	27	93	45	VCMT 160404	IS M3.5x10.0	0.12
300561	SL40 SVUCR CP ^b	50	28	27	93	45	VCMT 160404	IS M3.5x10.0	0.12

All cutter heads are delivered with the insert clamp screw and torx key

a - P - Peripheral coolant works for SL connection with 3C

b - CP - Central and Peripheral coolant works with SL connection with both 1C and 3C

c - available after Sep. 2023

Back boring – B-SVUCR for VCMT Inserts

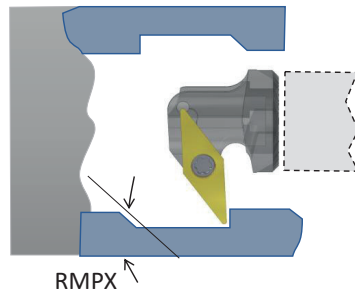
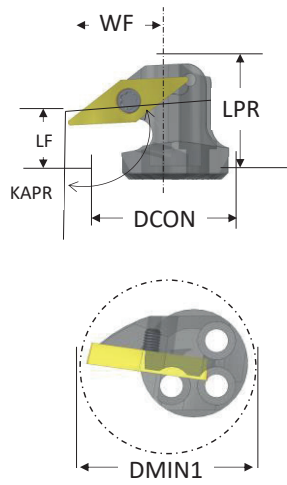

P – Peripheral coolant

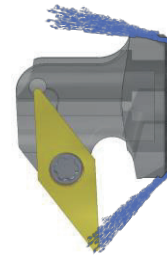

CP – Central and Peripheral coolant

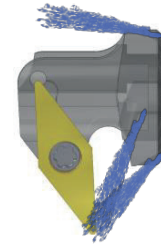

Part Number	Type	DMIN1 (mm)	LF (mm)	LPR (mm)	WF (mm)	KAPR (°)	RMPX (°)	Master insert	Insert screw	KG
300667	SL16 B SVUCR CP ^b	25	8	17	16	93	45	VCMT 110304	IS M2.5x6.0	0.02

All cutter heads are delivered with the insert clamp screw and torx key
 a - P - Peripheral coolant works for SL connection with 3C
 b - CP -Central and Peripheral coolant works with SL connection with both 1C and 3C

PDUNR, PDUNL for DNMG Inserts

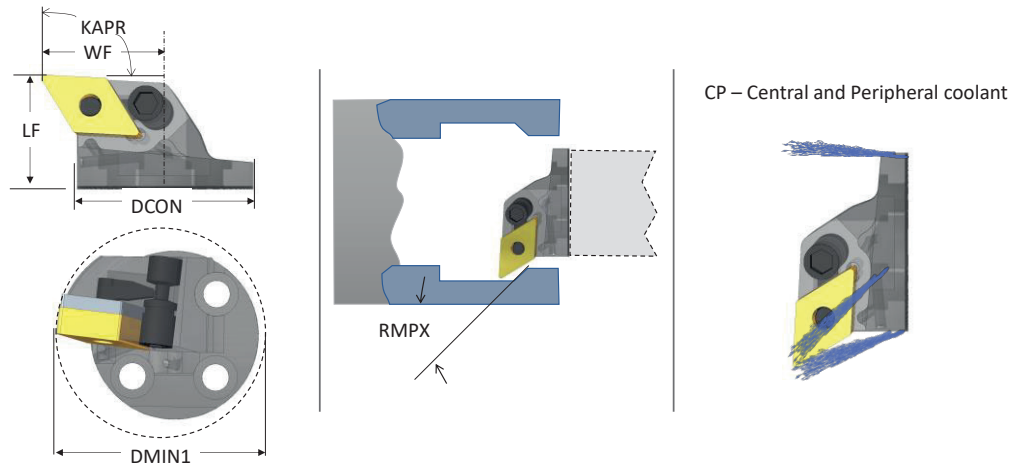

Part Number	Type	DMIN1 (mm)	LF (mm)	WF (mm)	KAPR (°)	RMPX (°)	Insert	Slot screw	Level	Shim	
300661	SL25 PDUNL CP ^a	34	23	19	93	27	DNMG 1104XX	M5x0.8x15	LV3 G0310	PS DNMG 1104	0.05
300660	SL25 PDUNR CP ^a	34	23	19	93	27	DNMG 1104XX	M5x0.8x15	LV3 G0310	PS DNMG 1104	0.05
300562	SL32 PDUNL CP ^a	40	26	22	93	27	DNMG 1104XX	M6x1x17	LV3 G0312	PS DNMG 1104	0.09
300427	SL32 PDUNR CP ^a	40	26	22	93	27	DNMG 1104XX	M6x1x17	LV3 G0312	PS DNMG 1104	0.09
300402	SL40 PDUNL CP ^a	50	26	30	93	27	DNMG 1506XX	M8x1x21	LV4 G0516	PS DNMG 1506	0.14
300086	SL40 PDUNR CP ^a	50	26	30	93	27	DNMG 1506XX	M8x1x21	LV4 G0516	PS DNMG 1506	0.14

All cutter heads are delivered with the insert clamp screw and torx key

a - CP -Central and Peripheral coolant works with SL connection with both 1C and 3C

PTFNR, PTFNL for TNMG Inserts

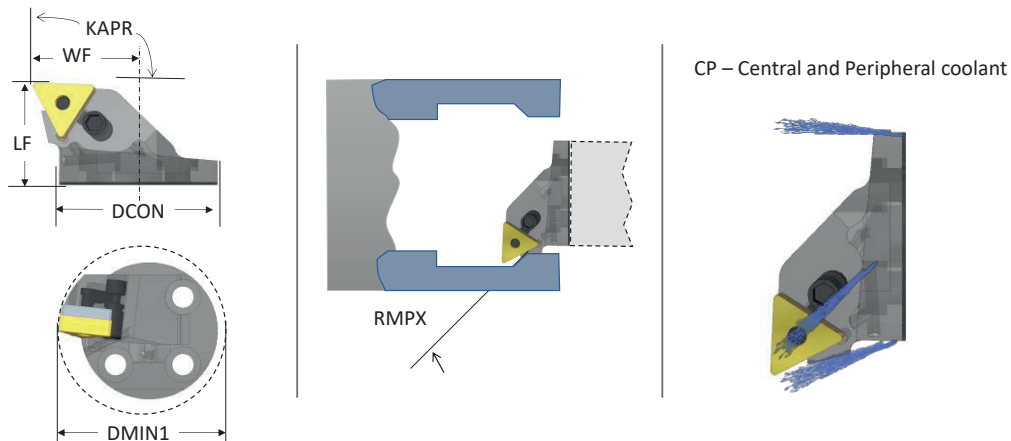

Part Number	Type	DMIN1 (mm)	LF (mm)	WF (mm)	KAPR (°)	RMPX (°)	Insert	Slot screw	Level	Shim	
300429	SL32 PTFNR CP ^a	40	27	22	91	NA	TNMG 1604XX	M6x1x17	LV3 G0310	PS TNMG 1604	0.09
300563	SL32 PTFNL CP ^a	40	27	22	91	NA	TNMG 1604XX	M6x1x17	LV3 G0310	PS TNMG 1604	0.09
300088	SL40 PTFNR CP ^a	50	26	27	91	NA	TNMG 1604XX	M6x1x17	LV3 G0310	PS TNMG 1604	0.14
300403	SL40 PTFNL CP ^a	50	26	27	91	NA	TNMG 1604XX	M6x1x17	LV3 G0310	PS TNMG 1604	0.14

All cutter heads are delivered with the insert clamp screw and torx key

a - CP -Central and Peripheral coolant works with SL connection with both 1C and 3C

PCLNR, PCLNL for CNMG Inserts

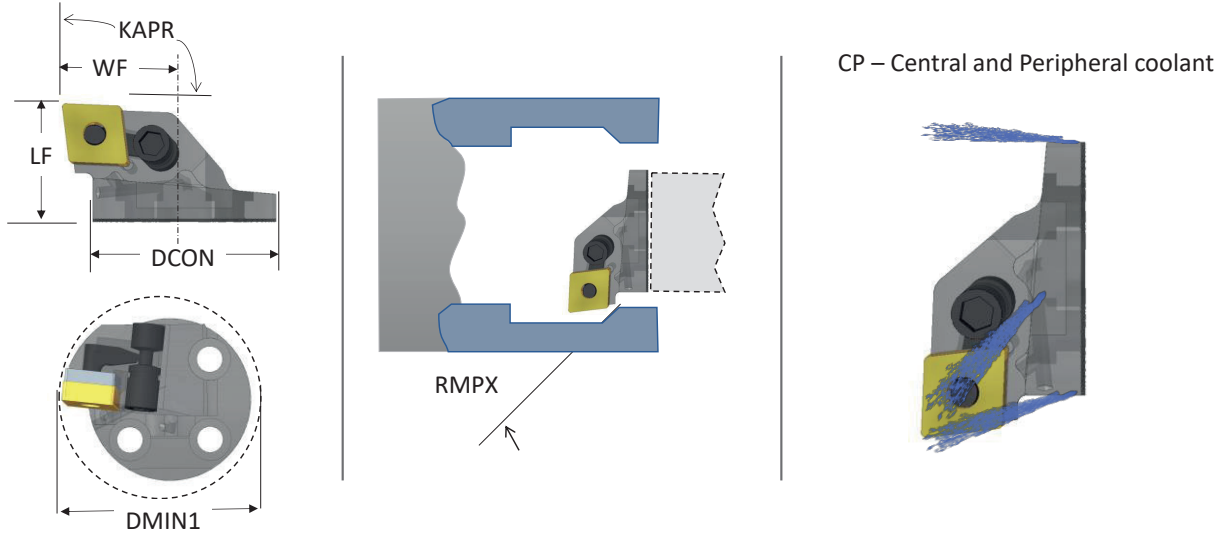

Part Number	Type	DMIN1 (mm)	LF (mm)	WF (mm)	KAPR (°)	RMPX (°)	Insert	Slot screw	Level	Shim	KG
300428	SL32 PCLNR CP ^a	40	26	22	95	NA	CNMG 1204XX	M6x1x17	LV4 G0513	PS CNMG 1204	0.09
300564	SL32 PCLNL CP ^a	40	26	22	95	NA	CNMG 1204XX	M6x1x17	LV4 G0513	PS CNMG 1204	0.09
300087	SL40PCLNR CP ^a	50	26	27	95	NA	CNMG 1204XX	M8x1x21	LV4 G0513	PS CNMG 1204	0.14
300404	SL40 PCLNL CP ^a	50	26	27	95	NA	CNMG 1204XX	M8x1x21	LV4 G0513	PS CNMG 1204	0.14

All cutter heads are delivered with the insert clamp screw and torx key
a - CP -Central and Peripheral coolant works with SL connection with both 1C and 3C

PWLNR, PWLNL for WNMG Inserts

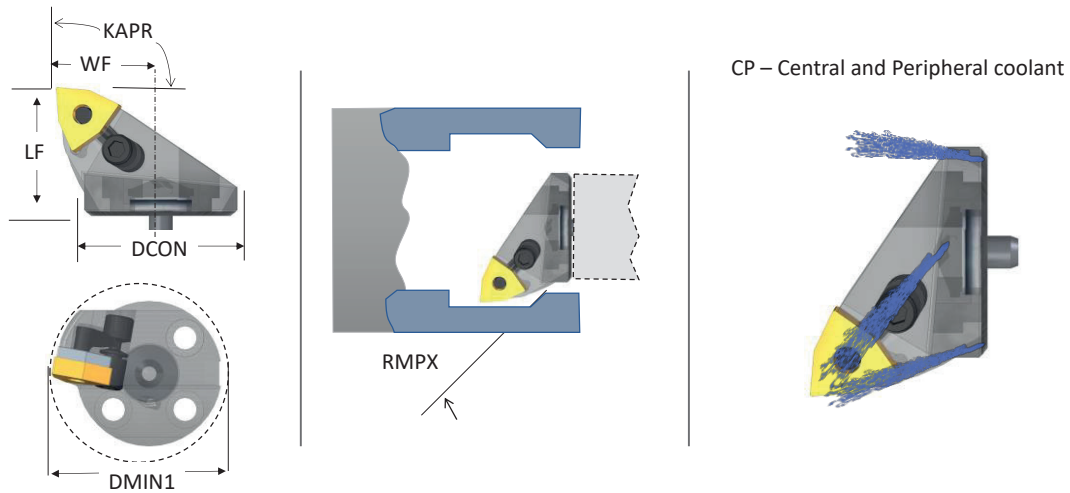

Part Number	Type	DCON (mm)	DMIN1 (mm)	LF (mm)	WF (mm)	KAP R (°)	RMPX (°)	Insert	Slot screw	Level	Shim	KG
300474	SL40 PWLNR CP ^a	SL 40	50	26	27	95	NA	WNMG 0804XX	M8x1x21	LV4 G0513	PS WNMG 0804	0.14
300475	SL40 PWLNL CP ^a	SL 40	50	26	27	95	NA	WNMG 0804XX	M8x1x21	LV4 G0513	PS WNMG 0804	0.14

All cutter heads are delivered with the insert clamp screw and torx key
a - CP -Central and Peripheral coolant works with SL connection with both 1C and 3C

End effectors - Threading

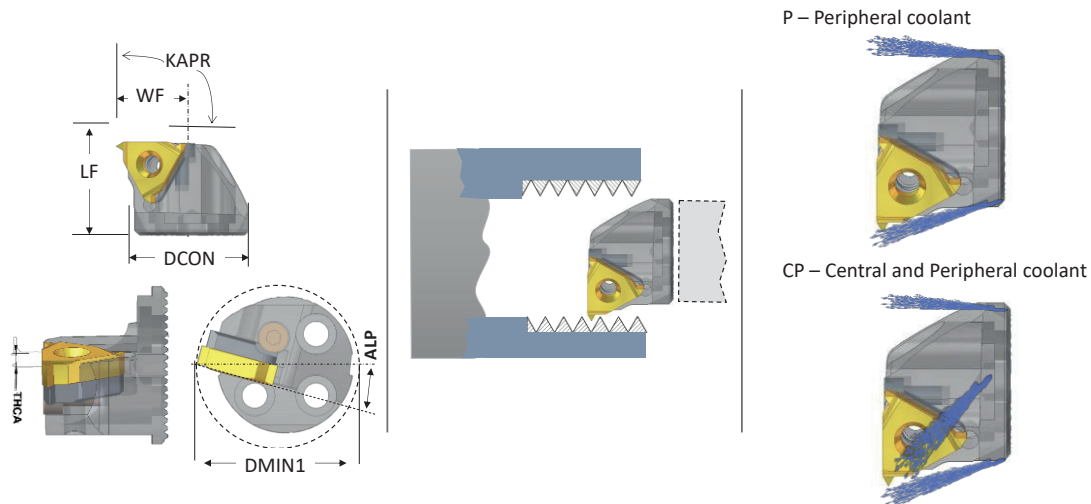

Left hand

Part Number	Type	DMIN1 (mm)	LF (mm)	WF (mm)	Master insert	Insert screw	Shim	Shim screw	ALP	THCA	KG
300268	SL12 SXFNL P ^a 11	16	16	8.9	11 IL A60	IS M2.5x6.0	NA	NA	15 °	2 °	0.01
300269	SL16 SXFNL P ^a 11	20	20	10.4	11 IL A60	IS M2.5x6.0	NA	NA	15 °	1 °	0.01
300270	SL16 SXFNL P ^a 16	20	20	10.4	16 IL AG60	IS M3.5x10.0	NA	NA	15 °	2 °	0.01
300271	SL20 SXFNL P ^a 11	25	20	12.7	11 IL A60	IS M2.5x6.0	NA	NA	15 °	1 °	0.02
300272	SL20 SXFNL P ^a 16	25	23	13.7	16 IL AG60	IS M3.5x11.0	NA	NA	15 °	2 °	0.02
300273	SL25 SXFNL P ^a 16	30	24	16.3	16 IL AG60	IS M3.5x11.0	EA16	HS M3x6	15 °	1 °	0.04
300274	SL25 SXFNL P ^a 22	32	30	18.3	22 IL N60	IS M4.5x12.0	EA22	HS M3x6	15 °	2 °	0.04
300275	SL32 SXFNL P ^a 16	37	28	19.7	16 IL AG60	IS M3.5x10.0	EA16	HS M3x6	15 °	1 °	0.07
300276	SL32 SXFNL CP ^b 22	39	32	21.7	22 IL N60	IS M4.5x12.0	EA22	HS M3x6	15 °	2 °	0.07
300277	SL40 SXFNL CP ^b 16	45	28	23.7	16 IL AG60	IS M3.5x10.0	EA16	HS M3x6	15 °	1 °	0.14
300278	SL40 SXFNL CP ^b 22	47	30	25.7	22 IL N60	IS M4.5x12.0	EA22	HS M3x6	15 °	2 °	0.14
300279	SL40 SXFNL CP ^b 27 ^c	48	35	26.8	27 IL Q60	IS M5.0x18.0	EA27	HS M4x9	15 °	2.5 °	0.14

Right hand

Part Number	Type	DMIN1 (mm)	LF (mm)	WF (mm)	Master insert	Insert screw	Shim	Shim screw	ALP	THCA	KG
300280	SL12 SXFN R P ^a 11	16	16	8.9	11 IR A60	IS M2.5x6.0	NA	NA	15 °	2 °	0.01
300281	SL16 SXFN R P ^a 11	20	20	10.4	11 IR A60	IS M2.5x6.0	NA	NA	15 °	1 °	0.01
300282	SL16 SXFN R P ^a 16	20	20	10.4	16 IR AG60	IS M3.5x10.0	NA	NA	15 °	2 °	0.01
300283	SL20 SXFN R P ^a 11	25	20	12.7	11 IR A60	IS M2.5x6.0	NA	NA	15 °	1 °	0.02
300284	SL20 SXFN R P ^a 16	25	23	13.7	16 IR AG60	IS M3.5x11.0	NA	NA	15 °	2 °	0.02
300285	SL25 SXFN R P ^a 16	30	24	16.3	16 IR AG60	IS M3.5x11.0	IA16	HS M3x6	15 °	1 °	0.04
300286	SL25 SXFN R P ^a 22	32	30	18.3	22 IR N60	IS M4.5x12.0	IA22	HS M3x6	15 °	2 °	0.04
300287	SL32 SXFN R P ^a 16	37	28	19.7	16 IR AG60	IS M3.5x10.0	IA16	HS M3x6	15 °	1 °	0.07
300288	SL32 SXFN R CP ^b 22	39	32	21.7	22 IR N60	IS M4.5x12.0	IA22	HS M3x6	15 °	2 °	0.07
300289	SL40 SXFN R CP ^b 16	45	28	23.7	16 IR AG60	IS M3.5x10.0	IA16	HS M3x6	15 °	1 °	0.14
300290	SL40 SXFN R CP ^b 22	47	30	25.7	22 IR N60	IS M4.5x12.0	IA22	HS M3x6	15 °	2 °	0.14
300291	SL40 SXFN R CP ^b 27	48	35	26.8	27 IR Q60	IS M5.0x18.0	IA27	HS M4x9	15 °	2.5 °	0.14

a - P - Peripheral coolant works for SL connection with 3C

b - CP - Central and Peripheral coolant works with SL connection with both 1C and 3C

c - Product on request.

All cutter heads are delivered with the insert clamp screw and torx key

Inserts are sold in packages of 10 pcs.

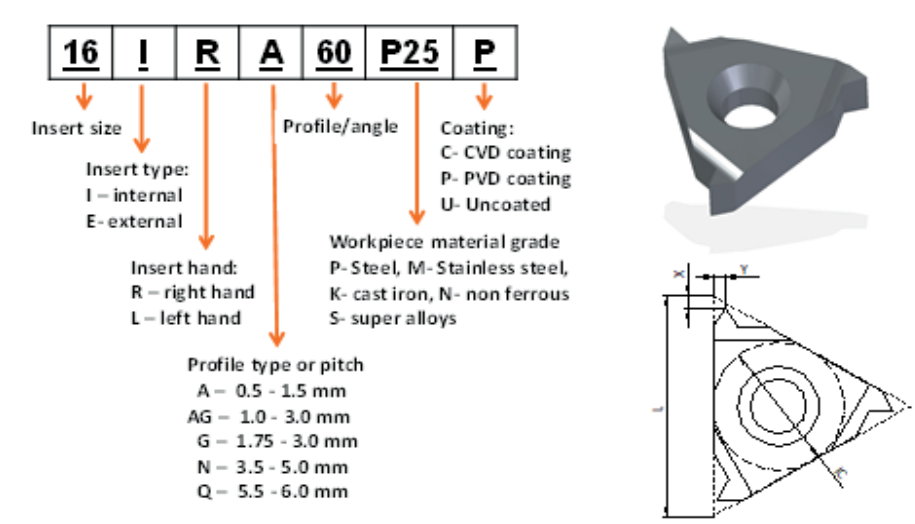

Left

Part Number	Type	Pitch mm (TPI)	IC	L	X	Y
300297	11 IL A60 P25P	0.5-1.5 (48-16)	6.350	11	0.8	0.9
300298	16 IL A60 P25P	0.5-1.5 (48-16)	9.525	16	0.8	0.9
300299	16 IL G60 P25P	1.75-3.0 (14-8)	9.525	16	1.2	1.7
300300	16 IL AG60 P25P	1.0-3.0 (26-8)	9.525	16	1.2	1.7
300301	22 IL N60 P25P	3.5-5.0 (7-5)	12.7	22	1.7	2.5
300302	27 IL Q60 P25P	5.5-6.0 (4.5-4)	15.875	27	2.1	3.1

Right

300303	11 IR A60 P25P	0.5-1.5 (48-16)	6.350	11	0.8	0.9
300304	16 IR A60 P25P	0.5-1.5 (48-16)	9.525	16	0.8	0.9
300305	16 IR G60 P25P	1.75-3.0 (14-8)	9.525	16	1.2	1.7
300306	16 IR AG60 P25P	1.0-3.0 (26-8)	9.525	16	1.2	1.7
300307	22 IR N60 P25P	3.5-5.0 (7-5)	12.7	22	1.7	2.5
300308	27 IR Q60 P25P	5.5-6.0 (4.5-4)	15.875	27	2.1	3.1
Other full profile inserts, with different standards are available upon request.						

End effectors – Grooving

KIGBA for GBA43 insert

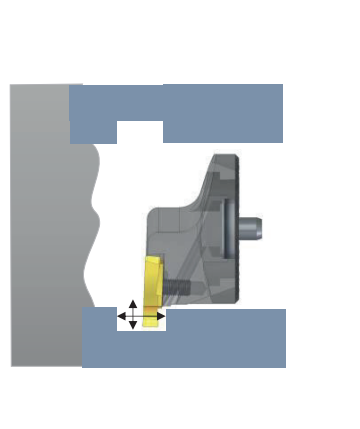
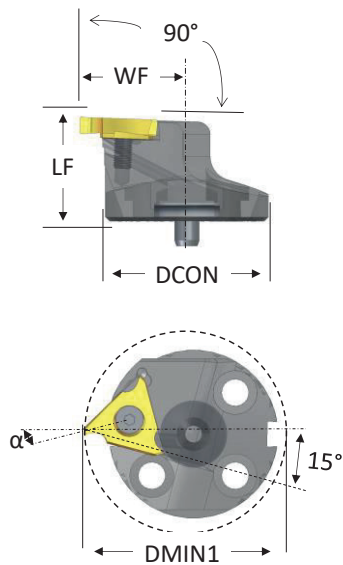

P – Peripheral coolant

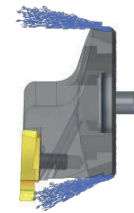

CP – Central and Peripheral coolant

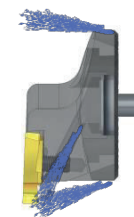

Part Number	Type	DMIN1 (mm)	LF (mm)	WF (mm)	Master insert	Insert screw	KG
300699	SL40 KIGBA R CP ^a GBA43	50	25	27	GBA43 L	IS M4.5x12	0.12
301169	SL40 KIGBA L CP ^a GBA43 ^b	50	25	27	GBA43 R	IS M4.5x12	0.12

a - Product available after 2024-April
b - CP -Central and Peripheral coolant works with SL connection with both 1C and 3C
All cutter heads are delivered with the insert clamp screw and torx key

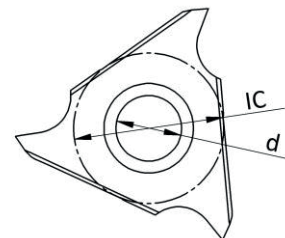
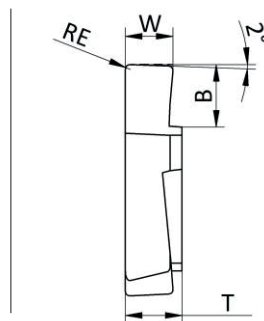

Part Number	Insert Type	IC	d	T	W	B	RE
301170	GBA43 R 100-010 P25C ^a	12.7	5.5	4.76	1.00	2.6	0.10
301171	GBA43 R 200-010 P25C ^a	12.7	5.5	4.76	2.00	4.1	0.10
301172	GBA43 R 300-010 P25C ^a	12.7	5.5	4.76	3.00	4.1	0.10
301173	GBA43 R 400-010 P25C ^a	12.7	5.5	4.76	4.00	5.2	0.10
301174	GBA43 L 100-010 P25C ^a	12.7	5.5	4.76	1.00	2.6	0.10
301175	GBA43 L 200-010 P25C ^a	12.7	5.5	4.76	2.00	4.1	0.10
301176	GBA43 L 300-010 P25C ^a	12.7	5.5	4.76	3.00	4.1	0.10
301177	GBA43 L 400-010 P25C ^a	12.7	5.5	4.76	4.00	5.2	0.10

^a Order KIG oriented product, 10 pcs/package, 2 weeks delivery time

End effectors – SL blanks

SL blanks Left hand

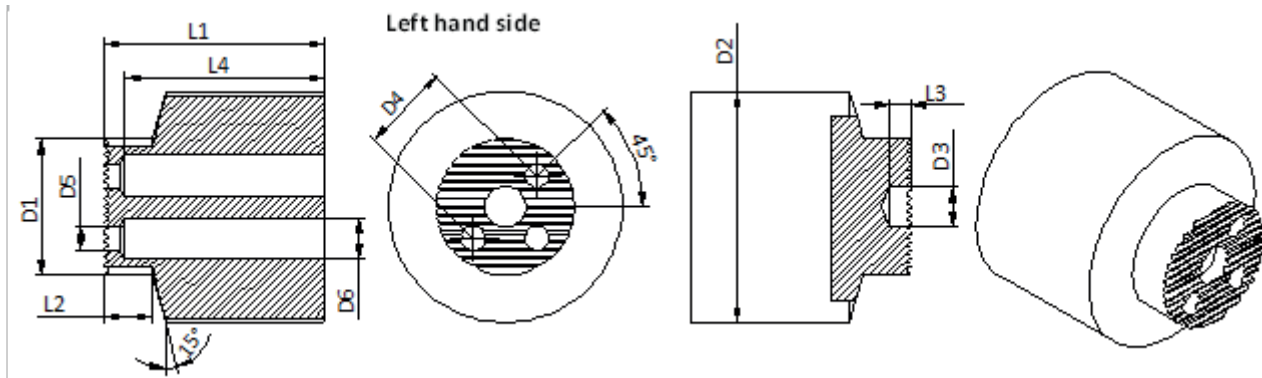

Left

Part Number	Type	D1 (mm)	D2 (mm)	D3 (mm)	D4 (mm)	D5 (mm)	D6 (mm)	L1 (mm)	L2 (mm)	L3 (mm)	L4 (mm)
300140	SL12-20-20 L	12	20	4	7.4	2.5	4	20	7	3	17
300142	SL16-26-25 L	16	26	4	9.5	3.5	6	25	7	3	22
300144	SL20-34-32 L	20	34	6	13	3.5	6	32	7	3	29
300146	SL25-40-40 L	25	40	6	16	4.5	7.5	40	7	3	37
300148	SL32-50-50 L	32	50	6	22	5.5	9	50	11	3	47
300150	SL40-60-60 L	40	60	6	28	6.5	10.5	60	11	3	57
300152	SL50-70-70 L	50	70	8	35	8.5	13.5	70	11	4	67

all SL blank parts will be supplied with a centering pin equivalent to the dimension

SL blanks Right hand

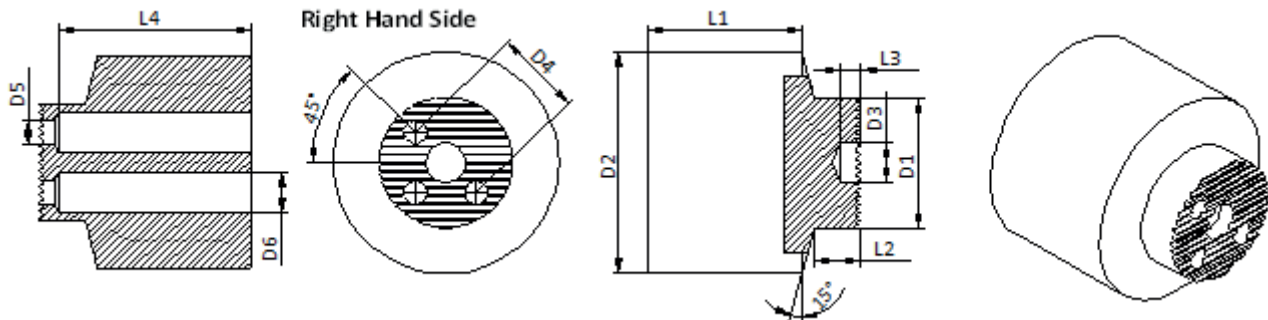

Right

Part Number	Type	D1 (mm)	D2 (mm)	D3 (mm)	D4 (mm)	D5 (mm)	D6 (mm)	L1 (mm)	L2 (mm)	L3 (mm)	L4 (mm)
300139	SL12-20-20 R	12	20	4	7.4	2.5	4	20	7	3	17
300141	SL16-26-25 R	16	26	4	9.5	3.5	6	25	7	3	22
300143	SL20-34-32 R	20	34	6	13	3.5	6	32	7	3	29
300145	SL25-40-40 R	25	40	6	16	4.5	7.5	40	7	3	37
300147	SL32-50-50 R	32	50	6	22	5.5	9	50	11	3	47
300149	SL40-60-60 R	40	60	6	28	6.5	10.5	60	11	3	57
300151	SL50-70-70 R	50	70	8	35	8.5	13.5	70	11	4	67

all SL blank parts will be supplied with a centering pin equivalent to the dimension

Inch

Part Number	Type	OD h6 (inch)	ID H7 (inch)	L (inch)	D (inch)	L1 (inch)	d (inch)
300229	RS i 1 ½ - 1 ¼	1.50	1.25	2.95	1.69	2.76	0.06
300230	RS i 1 ½ - 1	1.50	1.00	2.95	1.65	2.76	0.06
300231	RS i 1 ½ - ¾	1.50	0.75	2.95	1.65	2.76	0.06
300232	RS i 1 ½ - ⅝	1.50	0.625	2.95	1.65	2.76	0.06
300233	RS i 1 ½ - ½	1.50	0.50	2.95	1.65	2.76	0.06
300234	RS i 1 ½ - ⅜	1.50	0.375	2.95	1.65	2.76	0.06
300635	RS i 1 ½ - ⅕ ₁₆	1.50	0.3125	2.95	1.65	2.76	0.06

300235	RS i 1 ¼ - 1	1.25	1.00	2.56	1.46	2.36	0.04
300236	RS i 1 ¼ - ¾	1.25	0.75	2.56	1.46	2.36	0.04
300237	RS i 1 ¼ - ⅝	1.25	0.625	2.56	1.46	2.36	0.04
300238	RS i 1 ¼ - ½	1.25	0.50	2.56	1.46	2.36	0.04
300239	RS i 1 ¼ - ⅜	1.25	0.375	2.56	1.46	2.36	0.04
300636	RS i 1 ¼ - ⅕ ₁₆	1.25	0.3125	2.56	1.46	2.36	0.04

300639	RS i 2 - 1 ½	2.00	1.25	3.74	2.28	3.54	0.04
300640	RS i 2 - 1 ¼	2.00	1.50	3.74	2.28	3.54	0.04
300641	RS i 2 - 1	2.00	1.00	3.74	2.28	3.54	0.04

300642	RS i 2 ½ - 2	2.50	2.00	4.33	2.67	4.13	0.04
300643	RS i 2 ½ - 1 ½	2.50	1.50	4.33	2.67	4.13	0.04

300644	RS i 3 - 2 ½	3.00	2.50	5.04	3.46	4.84	0.04
300645	RS i 3 - 2	3.00	2.00	5.04	3.46	4.84	0.04

Level Indicator/Digital protractor (angle inclinometer)



Part Number	Product	Width (mm)	Length (mm)	Height (mm)	Weight (g)	Battery	Lightning
300175	Digital protractor - Level Indicator	26	57	55	85	AA. 2 pcs	Yes

Delivered with a magnet with power of 4.8 kg for easier alignment of machining tools.

Insert screws

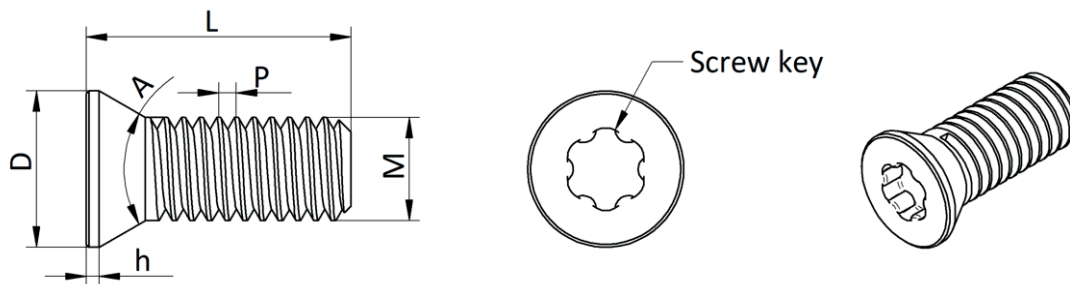

Insert screws

Part Number	Type - Torx	Quantity	Designation	Thread M	D (mm)	L (mm)	A (°)	P (mm)	h (mm)	Torx Key
300659	IS M2.0x4.0	10 pcs/bag	M2.0x4xD2.8xP0.4	M2.0	2.8	4	60	0.40	0.3	T6
300257	IS M2.2x5.0	10 pcs/bag	M2.2x5.0xD3.0xP0.45	M2.2	3.0	5.0	60	0.45	0.8	T7
300701	IS M2.5x4.5	10 pcs/bag	M2.5x4.5xD3.6xP0.45	M2.5	3.6	4.5	55	0.45	0.6	T8
300258	IS M2.5x6.0	10 pcs/bag	M2.5x6.0xD3.6xP0.45	M2.5	3.6	6.0	55	0.45	0.6	T8
300620	IS M2.5x8.0	10 pcs/bag	M2.5x8.0xD3.6xP0.45	M2.5	3.6	8.0	55	0.45	0.6	T8
300617	IS M3.5x11.0	10 pcs/bag	M3.5x11.0xD5.3xP0.60	M3.5	5.3	10.0	60	0.60	1.2	T15
300618	IS M4.0x15.0	10 pcs/bag	M4.0x15.0xD7.0xP0.70	M4.0	7.0	15.0	60	0.70	NA	T15
300619	IS M4.5x12.0	10 pcs/bag	M4.5x12.0xD6.8xP0.75	M4.5	6,8	12	60	0.75	NA	T20
300425	IS M5.0x18.0	10 pcs/bag	M5.0x18.0xD8.2xP0.8	M5.0	8,2	18	60	0.80	NA	T20

Cutter head screws

Standard: DIN 912

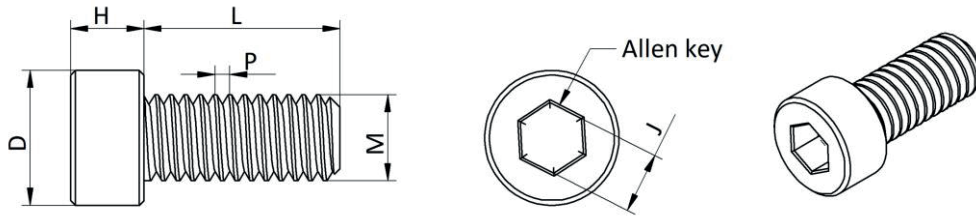

Cutter head screws

Part Number	Type (DIN912)	Quantity	Thread M	D (mm)	L (mm)	H (mm)	P (mm)	Key (mm)	Suitable for
300260	HS M2x8	10 pcs/bag	M2	3.8	8	2	0.4	Allen key A/F 1.5	SL12
300261	HS M2x14	10 pcs/bag	M2	3.8	14	2	0.4	Allen key A/F 1.5	SL12
300673	HS M3x6	10 pcs/bag	M3	5.5	6	3	0.5	Allen key A/F 2.5	EA16, IA16, EA22, IA22
300169	HS M3x8	10 pcs/bag	M3	5.5	8	3	0.5	Allen key A/F 2.5	SL16, SL20
300170	HS M4x9	10 pcs/bag	M4	7	9	4	0.7	Allen key A/F 3	SL25
300171	HS M5x12	10 pcs/bag	M5	8.5	12	5	0.8	Allen key A/F 4	SL32
300262	HS M6x14	10 pcs/bag	M6	10	14	6	1	Allen key A/F 5	SL40
300263	HS M8x14	10 pcs/bag	M8	13	14	8	1.25	Allen key A/F 6	SL50, SL60

Shims

Part Number	Type	Fits
300433	Shim CCMT 09T3	STMD M32-256 SCLCL/R C, STMD M40-320 SCLCL/R C
300430	Shim CCMT 1204	SL40 SCLCL/R CP
300431	Shim DCMT 11T3	SL40 SDUCL/R CP
300432	Shim TCMT 16T3	SL40 STFCL/R CP
300669	Shim VCMT 1604	SL40 SVUCL/R CP, SL32 SVUCL/R CP
300435	Shim EA16 - IL16	SL25 SXFNL P 16, SL32 SXFNL P 16, SL40 SXFNL CP 16
300436	Shim IA16 - IR16	SL25 SXFNR P 16, SL32 SXFNR P 16, SL40 SXFNR CP 16
300437	Shim EA22 - IL22	SL25 SXFNL P 22, SL32 SXFNL CP 22, SL40 SXFNL CP 22
300438	Shim IA22 - IR22	SL25 SXFNR P 22, SL32 SXFNR CP 22, SL40 SXFNR CP 22
300439	Shim EA27 - IL27	SL40 SXFNL CP 27
300440	Shim IA27 - IR27	SL40 SXFNR CP 27

Service kit for P clamp heads (includes level, shim, slot screw, spring)

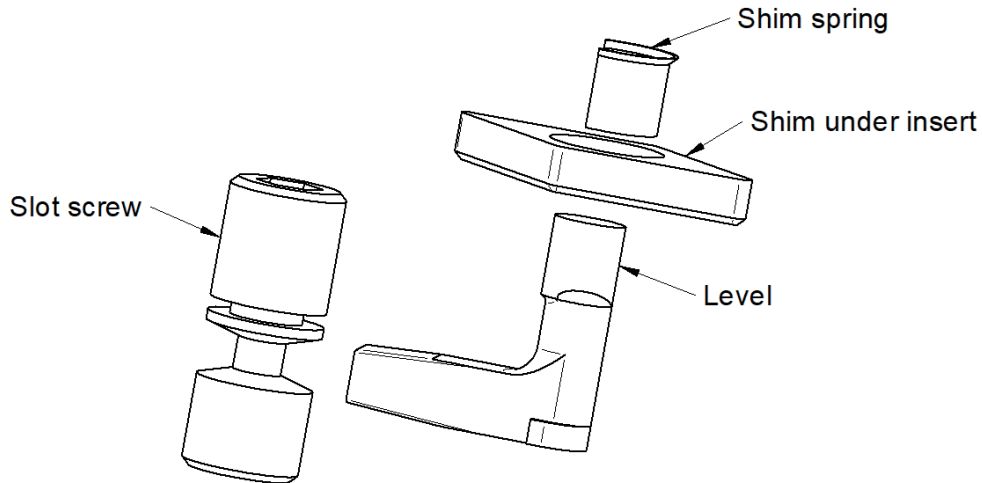

Part number	Service kit for	Cutter head	Level, 1 pcs	Shim, 1 pcs	Slot screw, 1 pcs	Spring, 1 pcs
300434	300086 300402	SL40 PDUNR CP SL40 PDUNL CP	LV4 G0516	Shim DNMG 1506	M8x1x21	T2-6
300426	300427 300562	SL32 PDUNR CP SL32 PDUNL CP	LV3 G0312	Shim DNMG 1104	M6x1x17	T1-5
301165	300661 300660	SL25 PDUNR CP SL25 PDUNL CP	LV3 G0310	Shim DNMG 1104	M5x0.8x15	T1-5
300471	300088 300403 300429 300563	SL40 PTFNR CP SL40 PTFNL CP SL32 PTFNR CP SL32 PTFNL CP	LV3 G0310	Shim TNMG 1604	M6x1x17	T1-5
300472	300087 300404	SL40 PCLNR CP SL40 PCLNL CP	LV4 G0513	Shim CNMG 1204	M8x1x21	T2-6
300473	300428 300564	SL32 PCLNR CP SL32 PCLNL CP	LV4 G0513	Shim CNMG 1204	M6x1x17	T2-6
300668	300474 300475	SL40 PWLNR CP SL40 PWLNL CP	LV4 G0513	Shim WNMG 0804	M8x1x21	T2-6

Coolant adapters for steel bars

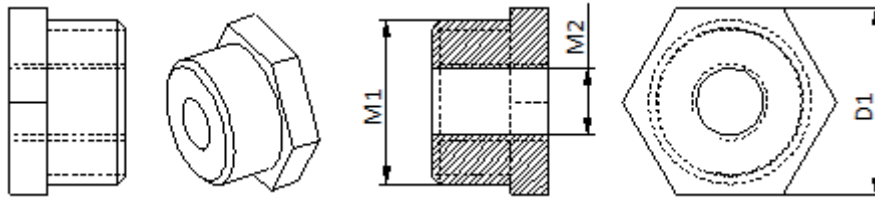

Steel bars

Part Number	Type	M1	M2	D1
300610	CA G ¼ - G ⅝	G ¼	G ⅝	17
300611	CA G ½ - G ¾	G ½	G ¾	24
300612	CA G ¾ - G 1 ¼	G ¾	G 1 ¼	30

Coolant adapters for carbide bars

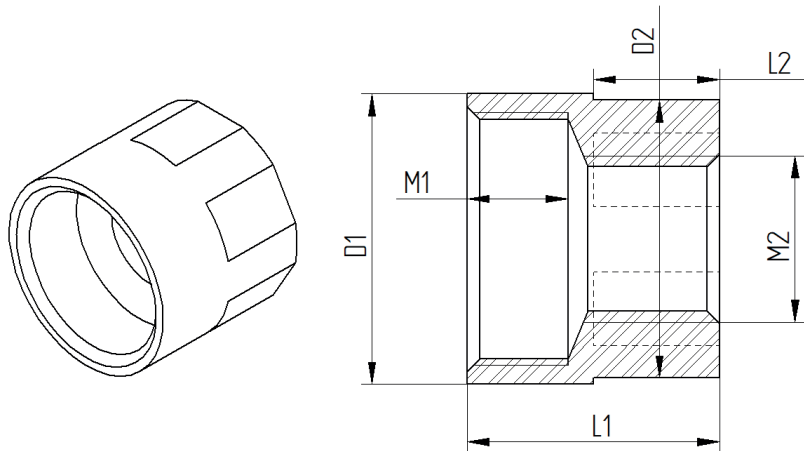

Carbide bars

Part Number	Type	M1	M2	L1	L2	D1	D2	Works for
300613	CA M12x1 G ⅝	M12x1	G ⅝	16	8	14	13	STMD M16-204 SL16, STMD M16-268 SL16 STMD I 5/8-8.0 SL16, STMD I 5/8-10.6 SL16
300614	CA M16x1 G ¾	M16x1	G ¾	20	10	18	16	STMD M20-260 SL20, STMD M20-340 SL20 STMD I 3/4-10.3 SL20, STMD I 3/4-13.4 SL20
300615	CA M20x1 G ¾	M20x1	G ¾	20	10	23	22	STMD M25-340 SL25, STMD I 1-16.9 SL25
300616	CA M24x1 G ¾	M24x1	G ¾	30	15	30	28	STMD M32-544 SL32, STMD I 1 1/4 -21.4 SL32

MAQ Master Inserts

Inserts are sold in packages of 10 pcs.

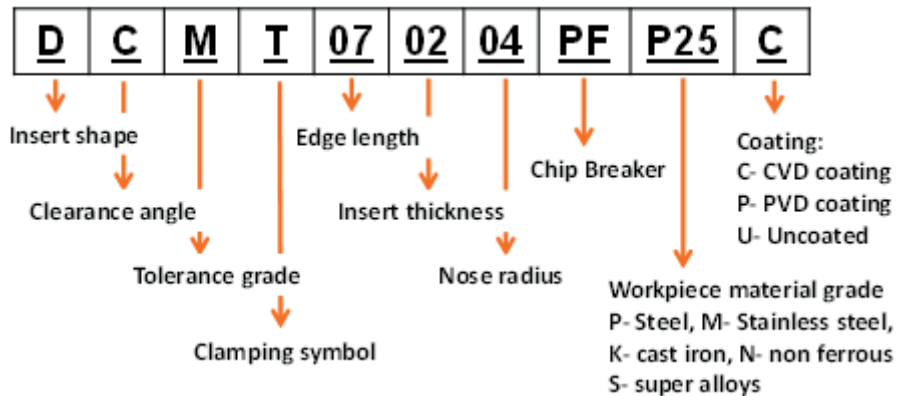

Positive insert

Part Number	Article	DCMT
300244	DCMT 070204-FP P25C	
300245	DCMT 11T304-FP P25C	

Part Number	Article	TCMT
300246	TCMT 090204-FP P25C	
300247	TCMT 110304-FP P25C	
300248	TCMT 16T304-FP P25C	

Part Number	Article	CCMT
300249	CCMT 060204-FP P25C	
300250	CCMT 09T304-FP P25C	
300251	CCMT 120404-FP P25C	

Negative insert

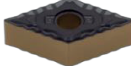
Part Number	Article	DNMG
300294	DNMG 150604-LC P25C	

Part Number	Article	TNMG
300295	TNMG 160404-LC P25C	

Part Number	Article	CNMG
300296	CNMG 120404 LC P25C	

FISSAGGIO DELLE BARRE ANTIVIBRANTI

Un bloccaggio inadeguato con una bassa rigidità alla flessione avrà un impatto negativo sulle prestazioni.

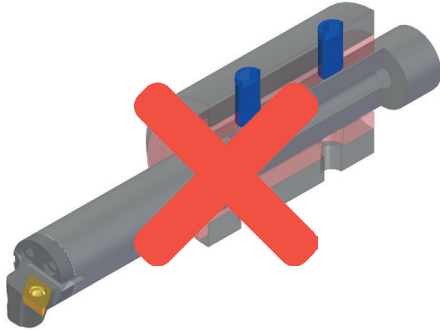

SERRAGGIO DIRETTO A VITE

- Rigidità finale inaccettabile
- Lunghezza di serraggio = NON APPLICABILE
- Non utilizzare su barre MAQ

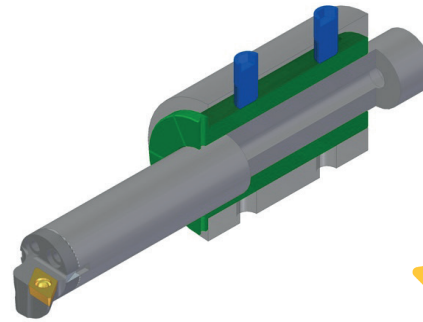

SERRAGGIO VITE + BUSSOLA

- Rigidità finale accettabile per basse sporgenze
- Lunghezza di serraggio consigliata minimo 3XD

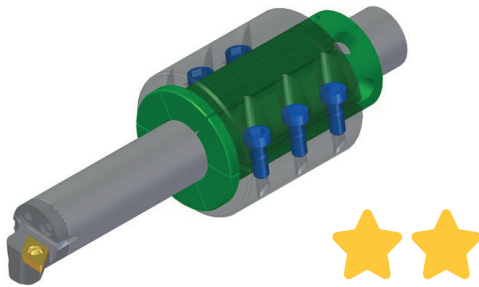

SERRAGGIO ELASTICO+BUSSOLA

- Buona rigidità alla flessione
- Lunghezza di serraggio consigliata minimo 3XD

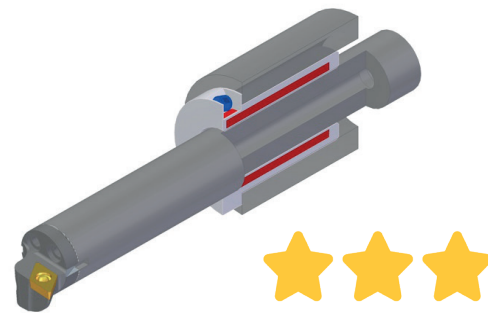

SERRAGGIO IDRAULICO

- Ottima rigidità alla flessione
- Consigliato per elevate sporgenze
- Lunghezza di serraggio consigliata minimo 2XD

BUSSOLA DI RIDUZIONE

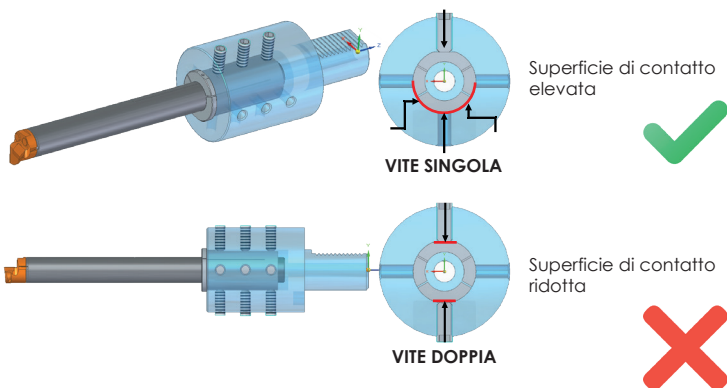

PREFERIRE PORTAUTENSILI CON SEZIONI ELEVATE

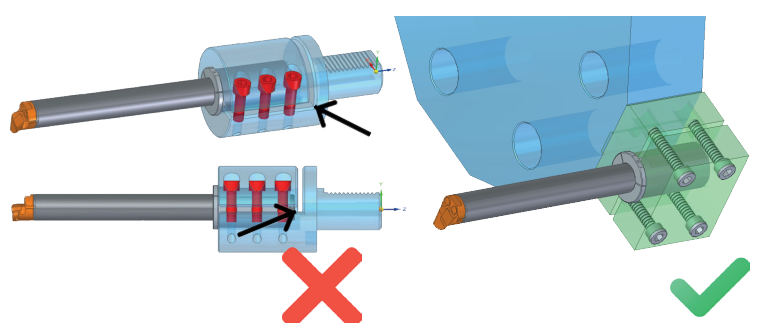

ATTACCHI MACCHINA

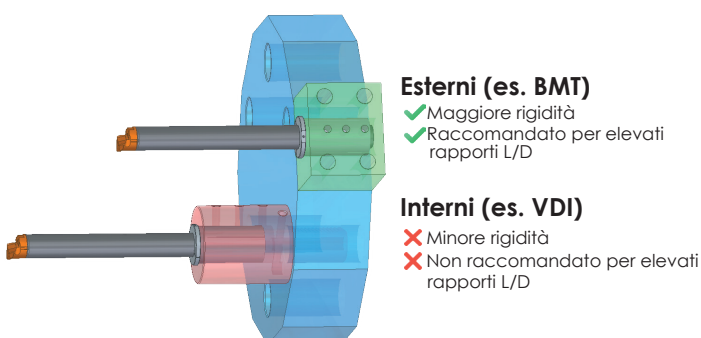

RIDURRE GLI SBALZI

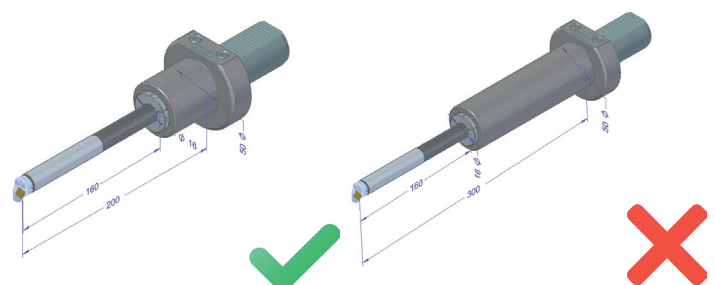

MMA



apm-trade

ALUISIO PIETRO & C. S.n.c

P.IVA/VAT N°: IT03878540263

 VIA A. DIAZ, 7 - 31046 ODERZO (TV) - ITALY

 PIETRO +39 3487155749

 MICHELE +39 3495253257

 aluisio.snc@gmail.com

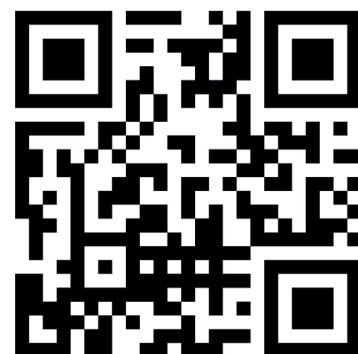

WWW.APM-TRADE.COM

apm-trade